



PVC Stargrip® series 4100HDP

Wedge Action Restraint for AWWA C900 PVC Pipe Bells

New Installations Only

Sizes 4" - 12"

INSTALLATION INSTRUCTIONS - SIZES 4" - 12"

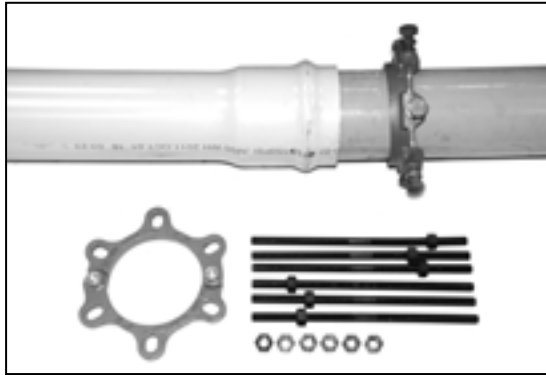

STEP 1

PVC Stargrip® Series 4100P is designed to restrain PVC Pipe, conforming to AWWA/ANSI AWWA C900/C900 (all pressure classes), push-on pipe bells. It includes a PVC Stargrip® Series 4000 gland for the spigot end and a split back-up ring behind the bell.

Place the PVC Stargrip® Series 4000 restraint gland on the spigot end of the second pipe with the lip extension facing towards the mating bell.

Assemble the PVC Pipe Push-On joint per the pipe manufacturer's installation instructions.

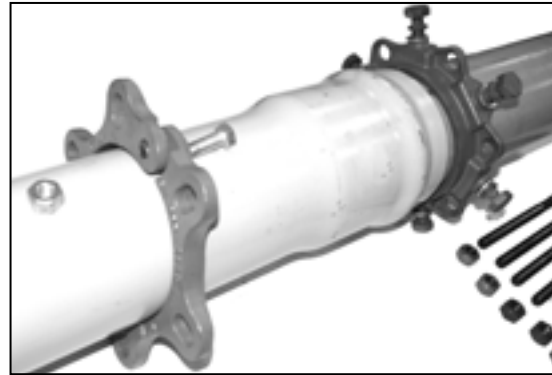

STEP 2

Install the split back up ring, behind the pipe bell in the direction indicated on the casting. Tighten clamping bolts on the split back-up ring to 90 ft-lb.

Rotate PVC Stargrip® Series 4000 restraint gland on the spigot such that the boltholes are in alignment and adjust the position so that the distance between the glands is suitable for the double-ended rod length. Adequate room should be allowed on the double-ended rods so that nuts can be fully engaged with several threads showing.

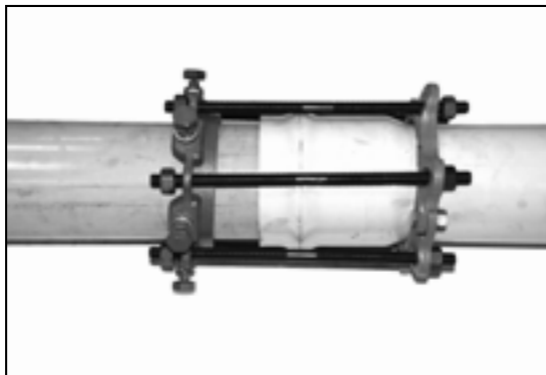

STEP 3

Install the remaining double-ended rods provided in each bolt hole for evenly distributing the operating load. Place nuts on the ends of each double-ended rod. It is to be ensured that adequate room is allowed on rods to fully engage the nuts with several threads showing.

Pull PVC Stargrip® Series 4000 restraint gland away from the joint until there is no slack in the rods.



STEP 4

Tighten the torque limiting twist off nuts in a clockwise direction until all the wedges are in firm contact with the pipe OD. Continue tightening in an alternating manner until all of the torque-limiting twist-off bolt heads have been twisted off.

The nuts on the double-ended rods must be tightened until the back-up ring is in firm contact with the back of the bell. These nuts should not be over tightened.

If removal of the PVC Stargrip® Series 4000 restraint gland is necessary, utilize the 5/8" hex head provided for 3" to 12". If reassembly is required, assemble the product in the same manner as above and tighten the wedge bolts to 90 ft-lbs.

Notes:

- Not to be used on DI or steel pipe.
- Stargrips must be adequately wrapped or protected if they are covered by concrete to ensure that concrete is not allowed to enter the wedge pocket.
- For applications with vertical offsets please contact Star Pipe Products for technical assistance.

STAR® PIPE PRODUCTS