



Super Flange™ series 7200

Designed for use on Ductile Iron, Steel, PVC, PVCO and HDPE Pipes

Ductile iron (3"-36"), Steel (3"-12"), PVC/PVCO/HDPE (3"-24")

Please refer to the approved pressure ratings table for approved pipe types by size.

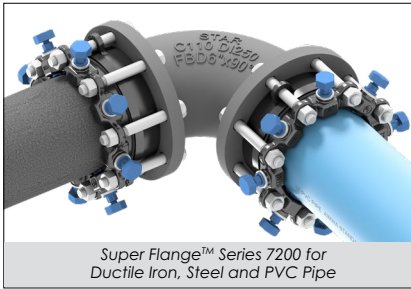

Super Flange™ Series 7200 for Ductile Iron, Steel and PVC Pipe

SUBMITTAL INFORMATION

PROJECT NAME:

ENGINEER:

CONTRACTOR:

SPEC. SECTION:



FEATURES & ADVANTAGES

- Versatile product designed for adapting ductile iron (3"-36"), PVC (3"-24") & steel (3"-12") pipe to flange connections.
- 350 psi maximum pressure rating on ductile iron pipe and rated to the maximum pressure rating of PVC pipe
- Approved on AWWA C900 PVC pipe, IPS PVC pipe, AWWA C909 PVCO pipe, and HDPE pipe. See pressure rating table for approved DRs and sizes. Plastic pressure pipes manufactured to an IPS diameter regimen will require a transition gasket.
- Joint deflection up to 5° maximum
- Allows for field flanged ends on plain end pipe
- Flange meets ANSI Class 125/150 and ANSI/AWWA C115/A21.15 drill pattern.
- Includes restraint gland, flange adapter ring, gaskets and hex head bolts/nuts
- Super Flange™ sizes 3"-12" are listed with Underwriters Laboratories Inc. and Underwriters Laboratories of Canada for ductile iron and steel pipe.
- Super Flange™ sizes 4" – 12" are approved by Factory Mutual Research for use on C900 PVC pipe DR18 Class 235 at 150 psi and sizes 4"-10" on DR14 Class 305 at 200 psi.
- Stargrip® may be used on steel pipe of any size. For steel pipe 12" and under a transition gasket is required if the diameter regimen is IPS. For steel pipe 14" and larger, the pipe's outside diameter must be the same as ductile iron pipe (CIOD diameter regimen). For sizes 3" – 8", minimum SCH40 steel pipe wall thickness is required. For sizes 10" through 16" the minimum wall thickness must be equal to or greater than PC350 ductile iron pipe. For sizes 18" and above, the minimum wall thickness of the steel pipe must be equal to or greater than PC 250 ductile iron pipe.

MATERIAL SPECIFICATIONS:

- Restraint Gland: Ductile Iron per ASTM A536, Grade 65-45-12
- Restraint Gland Finish: Starbond™ TGIC polyester powder coating applied by an electrostatic spray process
- Wedges: Ductile Iron per ASTM A536, Grade 65-45-12 heat treated to a minimum of 370 BHN
- Wedge Finish: Thermally cured fluoropolymer epoxy coating
- Flange adapter ring: coated with fusion bonded epoxy that meets ANSI/NSF 61
- MJ gasket and O-ring flange gasket are made from styrene butadiene rubber (SBR) per ANSI/AWWA C111/A-21.11.

GASKET TYPE (Please check one):

- Standard: MJ Gasket
- Option: Transition Gasket (3" to 12" only)

MJ GASKET MATERIAL OPTIONS (Please check one):

- Standard: Styrene butadiene rubber (SBR) per ANSI/AWWA C111/A-21.11
- Optional: EPDM
- Optional: NITRILE
- Other (specify) _____

HARDWARE OPTIONS (Please check one):

- Standard: hex head bolts and nuts are manufactured in accordance with ASTM A307, Grade B and ASTM A563 - bolts and nuts are also zinc plated.
- Optional: hex head bolts and nuts alloy SS 304 per ASTM F593 and ASTM A194
- Optional: hex head bolts and nuts alloy SS 316 per ASTM F593 and ASTM A194
- Optional: hex head bolts and nuts Fluoropolymer Star-Blue coated

STAR® PIPE PRODUCTS



Super Flange™ series 7200

Designed for use on Ductile Iron, Steel, PVC, PVCO and HDPE Pipes

Ductile iron (3"-36"), Steel (3"-12"), PVC/PVCO/HDPE (3"-24")

Please refer to the approved pressure ratings table for approved pipe types by size.

TECHNICAL INFORMATION

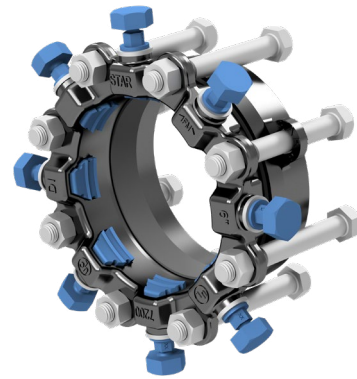
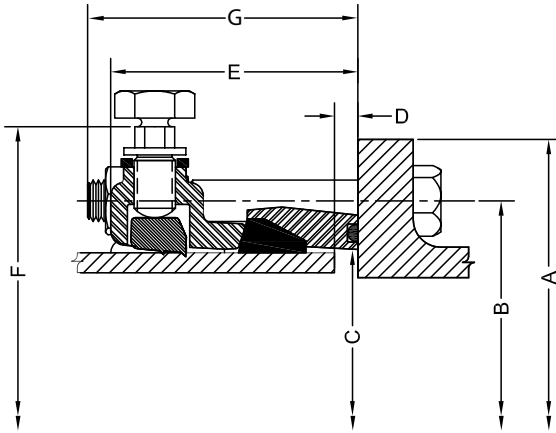

Please check size

SUPER FLANGE™ 7200 SPECIFICATIONS*											
NOM. SIZE	A	B	C	D MAX.	E	F	G	BOLTS		MAXIMUM JOINT DEFLECTION°	APPROX. WT. (LBS)
								SIZE	QTY.		
3	7.50	6.00	4.09	0.70	4.06	7.95	4.75	5/8 X 5 1/2	4	5.0°	13
4	9.00	7.50	4.93	0.60	4.18	9.22	4.56	5/8 X 5 1/2	8	5.0°	20
6	11.00	9.50	7.03	0.80	4.43	11.32	5.00	3/4 X 6	8	5.0°	29
8	13.50	11.75	9.18	0.90	4.60	13.29	4.88	3/4 X 6	8	5.0°	35
10	16.00	14.25	11.23	1.00	4.62	15.50	6.31	7/8 X 7 1/2	12	3.0°	60
12	19.00	17.00	13.33	1.00	4.75	17.50	6.25	7/8 X 7 1/2	12	3.0°	72
14	21.00	18.75	15.45	1.30	5.13	19.54	6.62	1 X 8	12	2.0°	89
16	23.50	21.25	17.55	1.30	5.18	21.64	6.56	1 X 8	16	2.0°	110
18	25.00	22.75	19.65	1.30	5.23	23.74	6.94	1 1/8 X 8 1/2	16	1.5°	140
20	27.50	25.00	21.75	1.30	5.24	25.84	6.81	1 1/8 X 8 1/2	20	1.5°	165
24	32.00	29.50	25.95	1.30	5.28	30.04	6.62	1 1/4 X 8 1/2	20	1.0°	198
30	38.75	36.00	32.18	2.00	6.00	36.58	7.88	1 1/4 X 10	28	1.0°	362
36	46.00	42.75	38.48	2.00	6.00	42.88	8.12	1 1/2 X 10 1/2	32	1.0°	541

* All dimensions in inches except where indicated.

Continue to next page for more
TECHNICAL INFORMATION >>

STAR® PIPE PRODUCTS



Super Flange™ series 7200

Designed for use on Ductile Iron, Steel, PVC, PVCO and HDPE Pipes

Ductile iron (3"-36"), Steel (3"-12"), PVC/PVCO/HDPE (3"-24")

Please refer to the approved pressure ratings table for approved pipe types by size.

TECHNICAL INFORMATION (cont'd)

TABLE A. Maximum Working Pressure Rating with Occasional or Recurring Surges in PSI for Pipes Made to a CIOD Diameter Regimen																		
NOM. SIZE (IN)	ACTUAL PLASTIC PIPE OD	DUCTILE IRON	AWWA C900 PVC									AWWA C909 PVCO	AWWA C906 HDPE*					
			DR14	DR17	DR18	DR21	DR25	DR27.5	DR32.5	DR41	DR51		PC235	DR 7.3	DR 9	DR 9.3	DR11	DR13.5
3	3.96	350	-	-	-	-	-	-	-	-	-	-	-	-	-	-	-	-
4	4.80	350	305	250	235	200	165	-	-	-	-	235	254	200	193	160	130	100
6	6.90	350	305	250	235	200	165	-	-	-	-	235	254	200	193	160	130	100
8	9.05	350	305	250	235	200	165	-	-	-	-	235	254	200	193	160	130	100
10	11.10	350	305	250	235	200	165	-	-	-	-	**	254	200	193	160	130	100
12	13.20	350	305	250	235	200	165	-	-	-	-	200	254	200	193	160	130	100
14	15.30	350	305	250	235	200	165	150	125	-	-	165	-	200	193	160	130	100
16	17.40	350	305	250	235	200	165	150	125	-	-	165	-	-	-	160	-	-
18	19.50	300	-	-	235	200	165	150	125	-	-	150	-	-	-	160	-	-
20	21.60	250	-	-	235	200	165	150	125	-	-	-	-	-	-	-	-	-
24	25.80	200	-	-	-	-	165	150	125	-	-	-	-	-	-	-	-	-
30	32.00	150	-	-	-	-	-	-	-	-	-	-	-	-	-	-	-	-
36	38.30	150	-	-	-	-	-	-	-	-	-	-	-	-	-	-	-	-

* A stainless steel pipe stiffener (provided by others) is required for the Series 7200 to be installed on HDPE pressure pipe. The stiffener must be installed in the HDPE pipe before installing the Series 7200. The stainless steel pipe stiffener must be of sufficient length to support the full bearing length of the restrainer.

** The Series 7200 is not recommended for 10-inch AWWA C909 PVCO pressure pipe.

TABLE B. Maximum Working Pressure Rating with Occasional or Recurring Surges in PSI for Pipes Made to an IPS Diameter Regimen											
NOM. SIZE (IN)	ACTUAL PLASTIC PIPE OD*	STEEL PIPE	ASTM D2241 PVC			AWWA C901 and AWWA C906 HDPE**					
			SDR17	SDR21	SDR26	DR 7.3	DR 9	DR 9.3	DR 11	DR 13.5	DR 17
3	3.50	350	250	200	160	254	200	-	160	130	100
4	4.50	350	250	200	160	254	200	193	160	130	100
6	6.63	350	250	200	160	254	200	193	160	130	100
8	8.63	350	250	200	160	254	200	193	160	130	100
10	10.75	350	250	200	160	254	200	193	160	130	100
12	12.75	350	250	200	160	254	200	193	160	130	100

* A transition gasket is required for use with pipes made to an IPS diameter regimen.

** A stainless steel pipe stiffener (provided by others) is required for the Series 7200 to be installed on HDPE pressure pipe. The stiffener must be installed in the HDPE pipe before installing the Series 7200. The stainless steel pipe stiffener must be of sufficient length to support the full bearing length of the restrainer.

STAR® PIPE PRODUCTS