



Ductile Iron MJ Full Body Fittings

ANSI/AWWA C110/A21.10

GENERAL SPECIFICATIONS

- MATERIAL:** Ductile iron per ASTM A536
- PRESSURE:** 350 PSI rating for 2" - 24" sizes, 250 PSI rating for 30" - 48" and 150 PSI for 54"-64" or as noted
- TESTING:** In accordance with ANSI/AWWA C110/A21.10
- LAYING LENGTH:** In accordance with ANSI/AWWA C110/A21.10 (fittings not listed in ANSI/AWWA have dimensions per Star design as noted in the catalog)
- WEIGHTS:** Are in pounds, unless noted otherwise and do not include accessories, cement lining and coating
- FLANGES:** Flanged ends on fittings match ANSI/AWW C110/A21.10 and ANSI B16.1 class 125 flanges.
- CEMENT LINING:** In accordance with ANSI/AWWA C104/A21.4 -- sizes 2" - 3" single thickness and sizes 4" - 54" double thickness
- COATING:** Asphaltic seal coat inside and out in accordance with ANSI/AWWA C104/A21.4 and referenced in ANSI/AWWA C110/A21.10
- GASKETS:** SBR in accordance with ANSI/AWWA C111/A21.11
- T-BOLTS/NUTS:** Low alloy steel in accordance with ANSI/AWWA C11/A21.11
- APPROVALS:** Sizes 2" and greater are UL/ANSI/NSF Standards 61 and 372
- DIMENSIONS:** All dimensions are in inches unless noted otherwise.
- INSTALLATION:** Per ANSI/AWWA C600 and C111 using DIP conforming to C150/C151 and PVC pipe conforming to C900/C905



SUBMITTAL INFORMATION	
PROJECT NAME:	<input style="width: 80%;" type="text"/>
ENGINEER:	<input style="width: 80%;" type="text"/>
CONTRACTOR:	<input style="width: 80%;" type="text"/>
SPEC. SECTION:	<input style="width: 80%;" type="text"/>

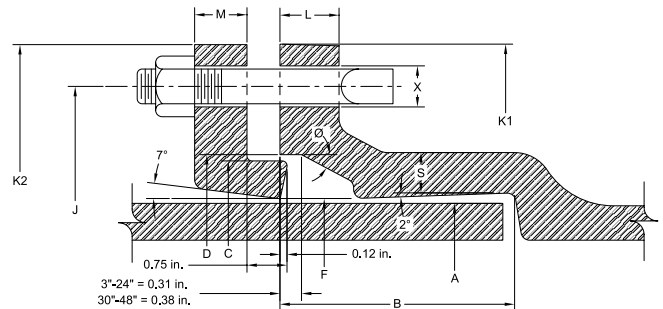

MECHANICAL JOINT DIMENSIONS															
NOM. SIZE	A DIA.	B	C DIA.	D DIA.	F DIA.	J DIA.	K1 DIA.	K2 DIA.	L	M	S	Ø	X DIA.	BOLTS	
														SIZE	NO.
2	2.50	2.50	3.39	3.50	2.61	4.75	6.25	6.25	0.75	0.62	0.44	28°	¾	⅝ x 3	2
3	3.96	2.50	4.84	4.94	4.06	6.19	7.69	7.69	0.94	0.62	0.52	28°	¾	⅝ x 3	4
4	4.80	2.50	5.92	6.02	4.90	7.50	9.12	9.12	1.00	0.75	0.65	28°	⅞	¾ x 3 ½	4
6	6.90	2.50	8.02	8.12	7.00	9.50	11.12	11.12	1.06	0.88	0.70	28°	⅞	¾ x 3 ½	6
8	9.05	2.50	10.17	10.27	9.15	11.75	13.37	13.37	1.12	1.00	0.75	28°	⅞	¾ x 4	6
10	11.10	2.50	12.22	12.34	11.20	14.00	15.69	15.62	1.19	1.00	0.80	28°	⅞	¾ x 4	8
12	13.20	2.50	14.32	14.44	13.30	16.25	17.94	17.88	1.25	1.00	0.85	28°	⅞	¾ x 4	8
14	15.30	3.50	16.40	16.54	15.44	18.75	20.31	20.25	1.31	1.25	0.89	28°	⅞	¾ x 4 ½	10
16	17.40	3.50	18.50	18.64	17.54	21.00	22.56	22.50	1.38	1.31	0.97	28°	⅞	¾ x 4 ½	12
18	19.50	3.50	20.60	20.74	19.64	23.25	24.83	24.75	1.44	1.38	1.05	28°	⅞	¾ x 4 ½	12
20	21.60	3.50	22.70	22.84	21.74	25.50	27.08	27.00	1.50	1.44	1.12	28°	⅞	¾ x 4 ½	14
24	25.80	3.50	26.90	27.04	25.94	30.00	31.58	31.50	1.62	1.56	1.22	28°	⅞	¾ x 5	16
30	32.00	4.00	33.29	33.46	32.17	36.88	39.12	39.12	1.81	2.00	1.50	20°	1 ½	1 x 6	20
36	38.30	4.00	39.59	39.76	38.47	43.75	46.00	46.00	2.00	2.00	1.80	20°	1 ½	1 x 6	24
42	44.50	4.00	45.79	45.96	44.67	50.62	53.12	53.12	2.00	2.00	1.95	20°	1 ¾	1 ¼ x 6 ½	28
48	50.80	4.00	52.09	52.26	50.97	57.50	60.00	60.00	2.00	2.00	2.20	20°	1 ¾	1 ¼ x 6 ½	32
54	{ Fittings & Dimensions Available On Request }														
60															
64															

- | | | |
|-------------------------------------|---|---|
| SIZE RANGE (Please specify): | LINING OPTIONS (Please check one): | COATING OPTIONS (Please check one): |
| Size Range _____ | Standard: Cement-lined and asphalt seal coat per ANSI/AWWA C104/A21.4 and UL/NSF-61
Optional: FBE (Fusion Bonded Epoxy) per ANSI/AWWA C116/A21.15 and UL/NSF-61 - ID & OD Only
Optional: P401 (Protecto 401) Ceramic Epoxy - sewer applications only. Not NSF-61
Optional: Other (specify) _____ | Standard: Asphaltic seal coat per ANSI/AWWA C104/A21.4
Optional: FBE (Fusion Bonded Epoxy) per ANSI/AWWA C116/A21.15 and UL/NSF-61 - ID & OD Only
Optional: Other (specify) _____ |

