



Flanged Fittings

ANSI/AWWA C110/A21.10

1" - 64" DUCTILE IRON FLANGED FITTINGS

GENERAL SPECIFICATIONS

- MATERIAL:** Ductile iron per ASTM A536
- PRESSURE:** 250 PSI rating for 1" - 48" sizes and 150 PSI rating for 54" - 64"
- TESTING:** In accordance with ANSI/AWWA C110/A21.10, UL and FM requirements
- LAYING LENGTH:** 2" - 48" sizes in accordance with ANSI/AWWA C110/A21.10 and ANSI B16.1 and 54" - 64" sizes in accordance with ANSI/AWWA C153/A21.53 (fittings not listed in ANSI/AWWA have dimensions per Star design as noted in the catalog)
- WEIGHTS:** Are in pounds, unless noted otherwise and do not include accessories, cement lining and coatings
- DRILLING:** In accordance with ANSI/AWWA C110/A21.10, ANSI/AWWA C153/A21.53 and ANSI B16.1 Class 125 Flanges
- CEMENT LINING:** In accordance with ANSI/AWWA C104/A21.4 -- sizes 1" - 3" single thickness and sizes 4" - 64" double thickness
- COATING:** Asphaltic seal coat inside in accordance with ANSI/AWWA C104/A21.4 and prime coat outside
- APPROVALS:** 2" - 12" Underwriters Laboratories and ULC Listed and Factory Mutual approved for 300 PSI rating. Please consult factory for detail listing and approvals. 2" and greater are UL/NSF-61.
- DIMENSIONS:** All dimensions are in inches unless noted otherwise.

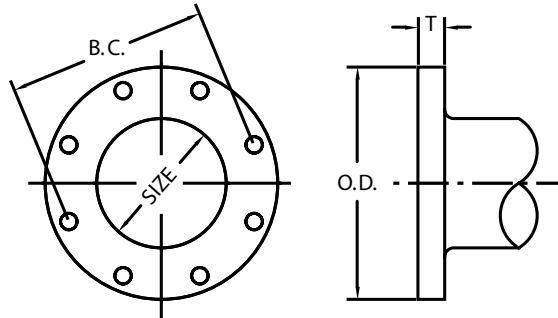

FLANGE DETAILS						
NOM. SIZE	O.D.	B.C.	T	BOLT HOLE DIA.	BOLTS	
					SIZE	NO.
1	4.25	3.12	0.44	0.62	1/2 x 2	4
1 1/2	5.00	3.88	0.56	0.62	1/2 x 2	4
2	6.00	4.75	0.62	0.75	5/8 x 2 1/4	4
2 1/2	7.00	5.50	0.69	0.75	5/8 x 2 1/2	4
3	7.50	6.00	0.75	0.75	5/8 x 2 1/2	4
4	9.00	7.50	0.94	0.75	5/8 x 3	8
5	10.00	8.50	0.94	0.88	3/4 x 3	8
6	11.00	9.50	1.00	0.88	3/4 x 3 1/2	8
8	13.50	11.75	1.12	0.88	3/4 x 3 1/2	8
10	16.00	14.25	1.19	1.00	7/8 x 4	12
12	19.00	17.00	1.25	1.00	7/8 x 4	12
14	21.00	18.75	1.38	1.13	1 x 4 1/2	12
16	23.50	21.25	1.44	1.13	1 x 4 1/2	16
18	25.00	22.75	1.56	1.25	1 1/8 x 5	16
20	27.50	25.00	1.69	1.25	1 1/8 x 5	20
24	32.00	29.50	1.88	1.38	1 1/4 x 5 1/2	20
30	38.75	36.00	2.12	1.38	1 1/4 x 6 1/2	28
36	46.00	42.75	2.38	1.63	1 1/2 x 7	32
42	53.00	49.50	2.62	1.63	1 1/2 x 7 1/2	36
48	59.50	56.00	2.75	1.63	1 1/2 x 8	44
54	66.25	62.75	3.00	2.00	1 3/4 x 8 1/2	44
60	73.00	69.25	3.12	2.00	1 3/4 x 9	52
64	80.00	76.00	3.38	2.00	1 3/4 x 9	52

STAR[®] PIPE PRODUCTS





Flanged Fittings

ANSI/AWWA C110/A21.10

METHOD OF DESIGNING OUTLETS OF REDUCING FITTINGS FOR SPECIFICATIONS

Reducing Tees

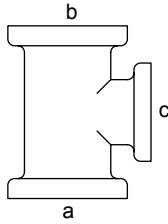

Reducing on Outlet

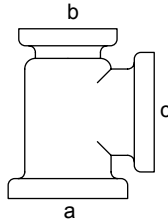

Reducing on One Run

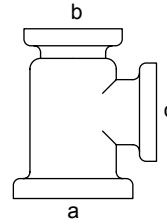

Reducing on One Run and Outlet

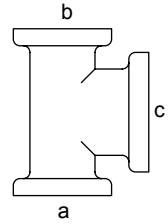

Reducing on Both Runs (Bull Head)

Reducing Crosses

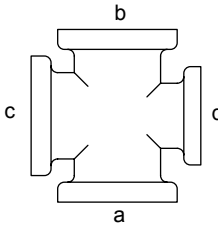

Reducing on One Outlet

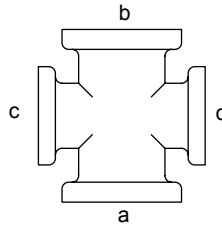

Reducing on Both Outlets

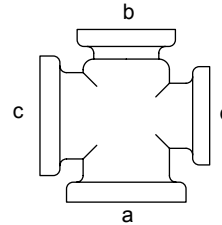

Reducing on One Run and Outlet

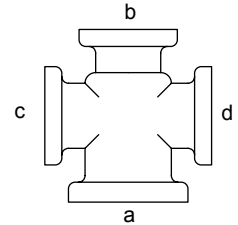

Reducing on One Run and Both Outlets

Reducing Laterals

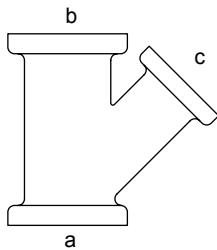

Reducing on Branch

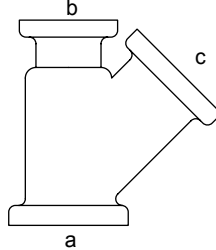

Reducing on One Run

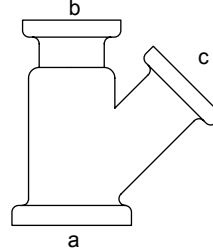

Reducing on One Run and Branch

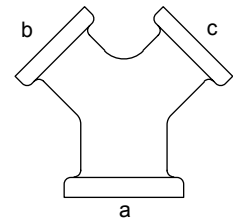

True Y

Side Outlet Tee

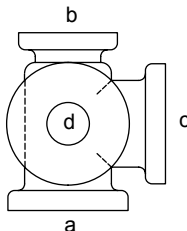

Right Hand

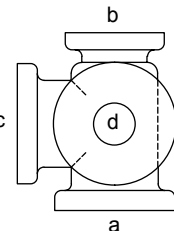

Left Hand

Double Branch Elbow

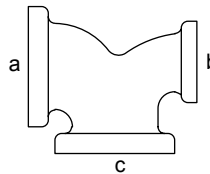

Side Outlet 90 deg. Elbow

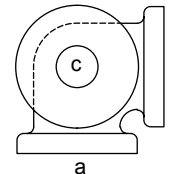

Right Hand

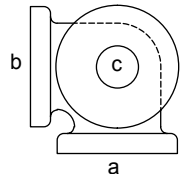

Left Hand

The largest opening establishes the basic size of a reducing fitting. The largest opening is named first, except for bull head tees which are reducing on both runs and double branch elbows where both branches are reducing; the outlet is the largest opening and named last in both cases.

In designating the opening of reducing fittings, they should be read in order indicated by the sequence of the letters a, b, c and d. In designating the outlets of side outlet of side outlet reducing fittings, the side outlet is named last; and in the case of the cross which is not shown, the side outlet is designated by the letter e.



STAR[®] PIPE PRODUCTS



Flanged Fittings

ANSI/AWWA C110/A21.10

METHOD OF DESIGNING LOCATION OF TAPPED HOLES FOR DRAINS WHEN SPECIFIED

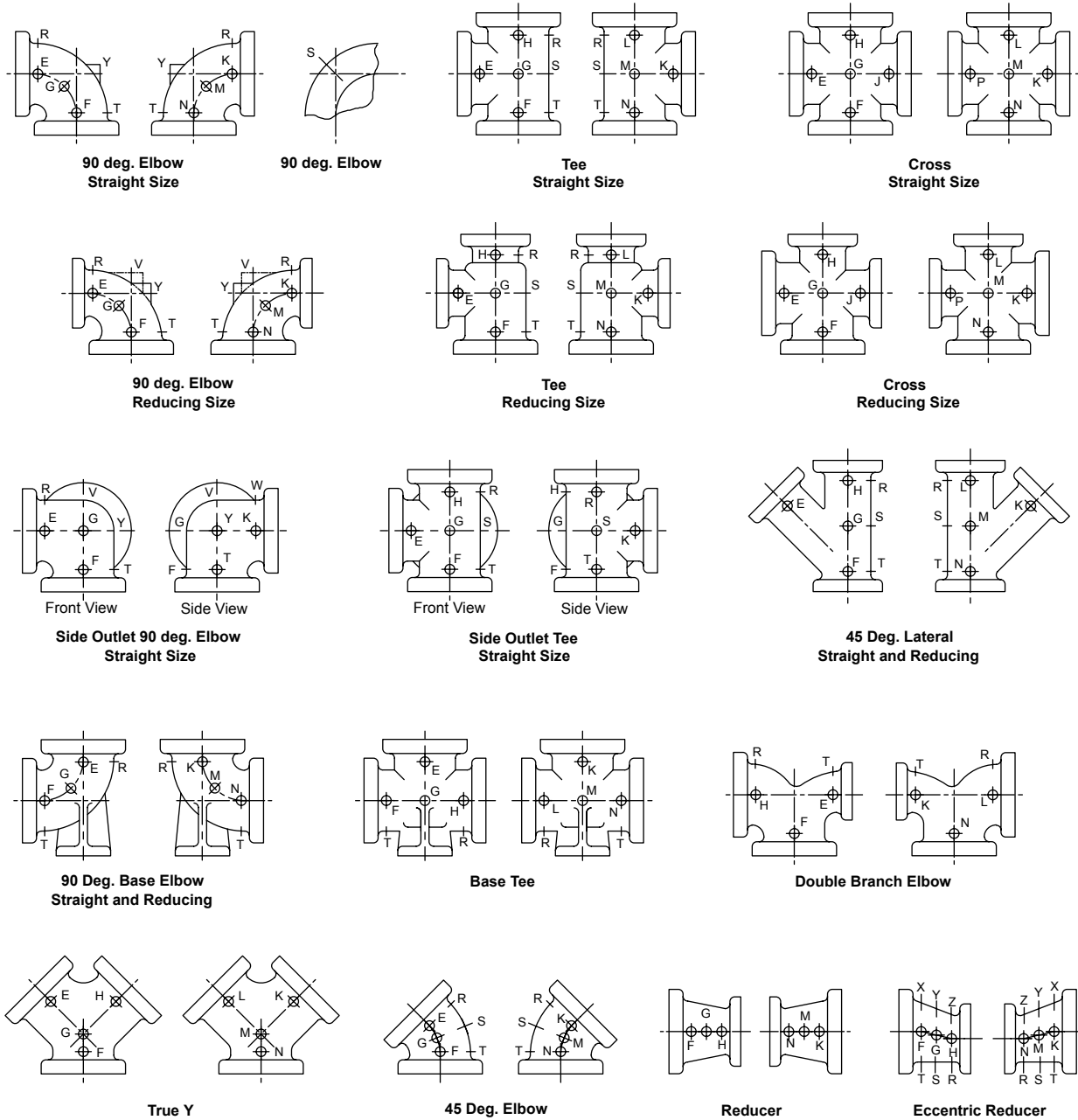

The above illustrations show two views of the same fitting and represent fittings with symmetrical shapes, with the exception of the side outlet elbow and the side outlet tee (straight sizes)

NOM. SIZE	MAX TAP SIZE WITHOUT BOSS
3	1/2
4-6	3/4
8	1 1/4
10-16	1 1/2
18-64	2

STAR[®] PIPE PRODUCTS





Flanged Fittings

ANSI/AWWA C110/A21.10

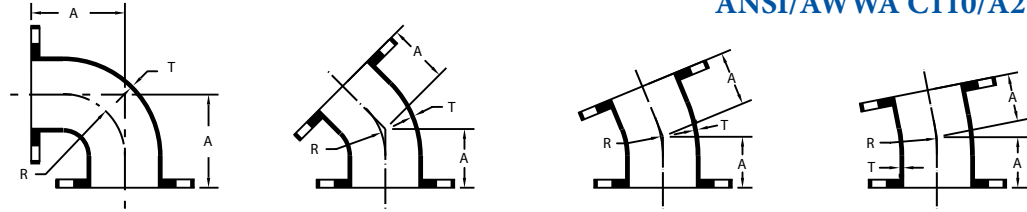

FLANGED BENDS		90° FLANGED BENDS (1/4)			45° FLANGED BENDS (1/8)			22 1/2° FLANGED BENDS (1/16)			11 1/4° FLANGED BENDS (1/32)		
NOM. SIZE	T	A	R	WT (LBS.)	A	R	WT (LBS.)	A	R	WT (LBS.)	A	R	WT (LBS.)
2	0.31	4.50	3.00	14	2.50	2.41	12	2.50	6.04	12	2.50	12.69	12
2 1/2	0.31	5.00	3.50	21	3.00	3.62	19	---	---	---	---	---	---
3	0.48	5.50	4.00	25	3.00	3.62	20	3.00	7.56	20	3.00	15.25	20
4	0.52	6.50	4.50	45	4.00	4.81	40	4.00	10.06	40	4.00	20.31	40
5	0.88	7.50	5.50	52	4.50	6.04	45	---	---	---	---	---	---
6	0.55	8.00	6.00	65	5.00	7.25	55	5.00	15.06	55	5.00	30.50	55
8	0.60	9.00	7.00	105	5.50	8.44	90	5.50	17.62	90	5.50	35.50	90
10	0.68	11.00	9.00	165	6.50	10.88	130	6.50	22.62	135	6.50	45.69	135
12	0.75	12.00	10.00	235	7.50	13.25	195	7.50	27.62	205	7.50	55.81	205
14	0.66	14.00	11.50	290	7.50	12.06	220	7.50	25.12	225	7.50	50.75	225
16	0.70	15.00	12.50	370	8.00	13.25	280	8.00	27.62	285	8.00	55.81	285
18	0.75	16.50	14.00	450	8.50	14.50	325	8.50	30.19	335	8.50	60.94	335
20	0.80	18.00	15.50	580	9.50	16.88	430	9.50	35.19	435	9.50	71.06	435
24	0.89	22.00	18.50	900	11.00	18.12	630	11.00	37.69	640	11.00	76.12	645
30	1.03	25.00	21.50	1430	15.00	27.75	1120	15.00	57.81	1135	15.00	116.75	1150
36	1.15	28.00	24.50	2135	18.00	35.00	1755	18.00	72.88	1790	18.00	147.25	1805
42	1.28	31.00	27.50	3055	21.00	42.25	2600	21.00	88.00	2665	21.00	177.69	2680
48	1.42	34.00	30.50	4095	24.00	49.50	3580	24.00	103.06	3665	24.00	208.12	3695
54	0.90	39.00	35.42	3740	20.50	41.05	2735	14.00	32.42	2260	12.00	30.81	2100
60	0.94	43.00	---	4965	23.50	---	3790	14.00	---	2985	10.50	---	2665
64	0.99	48.00	38.80	6745	25.00	---	5105	13.50	---	3995	9.50	---	3585

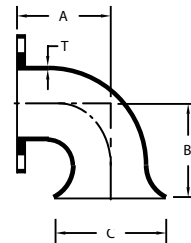
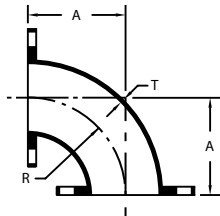

90° FLANGED LONG RADIUS BENDS				
NOM. SIZE	T	A	R	WT (LBS.)
3	0.48	7.75	6.25	30
4	0.52	9.00	7.00	50
6	0.55	11.50	9.50	80
8	0.60	14.00	12.00	140
10	0.68	16.50	14.50	215
12	0.75	19.00	17.00	325
14	0.66	21.50	19.00	400
16	0.70	24.00	21.50	525
18	0.75	26.50	24.00	750
20	0.80	29.00	26.50	875
24	0.89	34.00	30.50	1250
30	1.03	41.50	38.00	2105
36	1.15	49.00	45.50	3285
42	1.28	56.50	53.00	4865
48	1.42	64.00	60.50	7800
54	0.90	73.50	69.50	6205

90° FLANGE x FLARE BENDS					
NOM. SIZE	T	A	B	C	WT (LBS.)
3	0.48	5.50	11.00	7.50	25
4	0.52	6.50	12.00	9.00	40
6	0.55	8.00	12.00	11.00	70
8	0.60	9.00	14.00	13.50	110
10	0.68	11.00	17.00	16.00	175
12	0.75	12.00	18.00	19.00	245
14	0.66	14.00	20.00	21.00	260
16	0.70	15.00	21.00	23.50	460
18	0.75	16.50	22.50	25.00	560
20	0.80	18.00	24.00	27.50	700
24	0.89	22.00	28.00	32.00	1100
30	1.03	25.00	32.00	38.75	1640
36	1.15	28.00	35.00	46.00	2700
42	1.28	31.00	38.00	53.00	3250
48	1.42	34.00	41.00	59.50	4215
54	0.90	39.00	46.00	66.25	3965

UCAT12.01
 * REGISTERED TRADEMARK OF STAR PIPE PRODUCTS



STAR[®] PIPE PRODUCTS



Flanged Fittings

ANSI/AWWA C110/A21.10

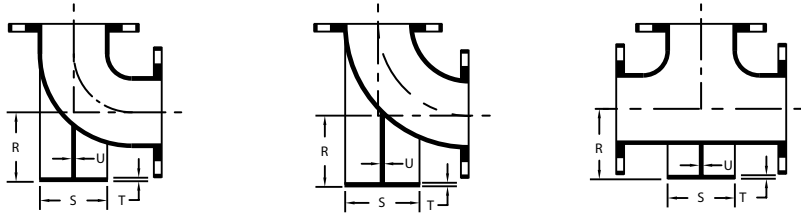

90° FLANGED LONG RADIUS BASE BENDS & BASE TEES

NOM. SIZE	R	S	T	U	WT. (LBS.)		
					90°	90°LR	TEE
2	4.12	4.62	0.50	0.50	17	---	23
2 1/2	4.50	4.62	0.50	0.50	25	---	34
3	4.88	5.00	0.56	0.50	35	40	45
4	5.50	6.00	0.62	0.50	55	60	75
5	6.25	7.00	0.69	0.62	70	85	95
6	7.00	7.00	0.69	0.62	85	100	110
8	8.38	9.00	0.94	0.88	145	180	185
10	9.75	9.00	0.94	0.88	210	260	300
12	11.25	11.00	1.00	1.00	300	390	430
14	12.50	11.00	1.00	1.00	320	650	500
16	13.75	11.00	1.00	1.00	445	815	600
18	15.00	13.50	1.12	1.12	565	955	740
20	16.00	13.50	1.12	1.12	700	1200	930
24	18.50	13.50	1.12	1.12	1030	1770	1410
30	23.00	16.00	1.19	1.15	1625	2295	2270
36	26.00	19.00	1.25	1.15	2385	3535	3320
42	30.00	23.50	1.44	1.28	3465	5275	5850
48	34.00	25.00	1.56	1.42	4610	7305	7720
54	38.00	27.50	1.69	1.55	4415	6880	6465

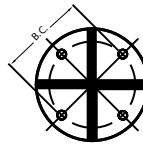
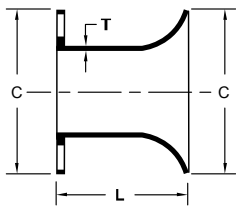

STRAIGHT FLANGE x FLARE PIECES				
NOM. SIZE	T	L	C	WT (LBS.)
3	0.48	8.00	7.50	20
4	0.52	8.00	9.00	30
6	0.55	8.00	11.00	40
8	0.60	10.00	13.50	70
10	0.68	10.00	16.00	95
12	0.75	12.00	19.00	155
14	0.66	12.00	21.00	165
16	0.70	16.00	23.50	240
18	0.75	16.00	25.00	275
20	0.80	18.00	27.50	360
24	0.89	18.00	32.00	480
30	1.03	24.00	38.75	850
36	1.15	24.00	46.00	1200
42	1.28	30.00	53.00	1900
48	1.42	30.00	59.50	2300
54	0.90	36.00	66.25	2225

BASE DRILLING DETAILS			
NOM. SIZE	B.C.	BOLT HOLE DIA.	NO. OF BOLTS
2	3.50	0.63	4
2 1/2	3.50	0.63	4
3	3.88	0.63	4
4	4.75	0.75	4
5	5.50	0.75	4
6	5.50	0.75	4
8	7.50	0.75	4
10	7.50	0.75	4
12	9.50	0.88	4
14	9.50	0.88	4
16	9.50	0.88	4
18	11.75	0.88	4
20	11.75	0.88	4
24	11.75	0.88	4
30	14.25	1.00	4
36	17.00	1.00	4
42	21.25	1.13	4
48	22.75	1.25	4
54	25.00	1.25	4

STAR[®] PIPE PRODUCTS



UCAT12.01
* REGISTERED TRADEMARK OF STAR PIPE PRODUCTS

STAR PIPE PRODUCTS
HOUSTON CORPORATE TOLL FREE 1-800-999-3009 FAX 281-558-9000
www.starpipeproducts.com



Flanged Fittings

ANSI/AWWA C110/A21.10

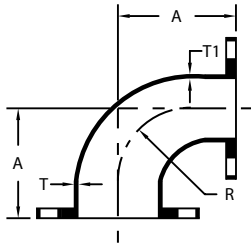

90° FLANGED REDUCING BENDS					
NOM. SIZE	T	T1	A	R	WT (LBS.)
3 x 1 1/2	0.48	0.31	5.50	4.00	18
3 x 2	0.48	0.31	5.50	4.00	20
3 x 2 1/2	0.48	0.31	5.50	4.00	23
4 x 2	0.52	0.31	6.50	4.50	29
4 x 2 1/2	0.52	0.31	6.50	4.50	33
4 x 3	0.52	0.48	6.50	4.50	35
5 x 2	0.50	0.31	7.50	5.50	42
5 x 2 1/2	0.50	0.31	7.50	5.50	44
5 x 3	0.50	0.48	7.50	5.50	45
5 x 4	0.50	0.50	7.50	5.50	50
6 x 2	0.55	0.31	8.00	6.00	40
6 x 2 1/2	0.55	0.31	8.00	6.00	44
6 x 3	0.55	0.48	8.00	6.00	45
6 x 4	0.55	0.52	8.00	6.00	55
6 x 5	0.55	0.50	8.00	6.00	60
8 x 4	0.60	0.52	9.00	7.00	80
8 x 5	0.60	0.50	9.00	7.00	80
8 x 6	0.60	0.55	9.00	7.00	90
10 x 4	0.68	0.52	11.00	9.00	105
10 x 6	0.68	0.55	11.00	9.00	125
10 x 8	0.68	0.60	11.00	9.00	150
12 x 6	0.75	0.55	12.00	10.00	165
12 x 8	0.75	0.60	12.00	10.00	190
12 x 10	0.75	0.68	12.00	10.00	220
14 x 6	0.66	0.55	14.00	11.50	144
14 x 8	0.66	0.60	14.00	11.50	200
14 x 10	0.66	0.68	14.00	11.50	260
14 x 12	0.66	0.75	14.00	11.50	270
16 x 6	0.70	0.55	15.00	12.50	220
16 x 8	0.70	0.60	15.00	12.50	240
16 x 10	0.70	0.68	15.00	12.50	344
16 x 12	0.70	0.75	15.00	12.50	373
16 x 14	0.70	0.66	15.00	12.50	330
18 x 6	0.75	0.55	16.50	14.00	260
18 x 8	0.75	0.60	16.50	14.00	280
18 x 10	0.75	0.68	16.50	14.00	320
18 x 12	0.75	0.75	16.50	14.00	465
18 x 14	0.75	0.66	16.50	14.00	370
18 x 16	0.75	0.70	16.50	14.00	410
20 x 6	0.80	0.55	18.00	15.50	320
20 x 8	0.80	0.60	18.00	15.50	345
20 x 10	0.80	0.68	18.00	15.50	385
20 x 12	0.80	0.75	18.00	15.50	415
20 x 14	0.80	0.66	18.00	15.50	518

(Con't)

90° FLANGED REDUCING BENDS (Con't)					
NOM. SIZE	T	T1	A	R	WT (LBS.)
20 x 16	0.80	0.70	18.00	15.50	533
20 x 18	0.80	0.75	18.00	15.50	515
24 x 6	0.89	0.55	22.00	18.50	480
24 x 8	0.89	0.60	22.00	18.50	505
24 x 10	0.89	0.68	22.00	18.50	545
24 x 12	0.89	0.75	22.00	18.50	795
24 x 14	0.89	0.66	22.00	18.50	837
24 x 16	0.89	0.70	22.00	18.50	635
24 x 18	0.89	0.75	22.00	18.50	675
24 x 20	0.89	0.80	22.00	18.50	740
30 x 12	1.03	0.75	25.00	21.50	840
30 x 14	1.03	0.66	25.00	21.50	860
30 x 16	1.03	0.70	25.00	21.50	900
30 x 18	1.03	0.75	25.00	21.50	940
30 x 20	1.03	0.80	25.00	21.50	1005
30 x 24	1.03	0.89	25.00	21.50	1205
36 x 12	1.15	0.75	28.00	24.50	1195
36 x 14	1.15	0.66	28.00	24.50	1215
36 x 16	1.15	0.70	28.00	24.50	1255
36 x 18	1.15	0.75	28.00	24.50	1295
36 x 20	1.15	0.80	28.00	24.50	1315
36 x 24	1.15	0.89	28.00	24.50	1520
36 x 30	1.15	1.03	28.00	24.50	1785
42 x 12	1.28	0.75	31.00	27.50	1655
42 x 14	1.28	0.66	31.00	27.50	1675
42 x 16	1.28	0.70	31.00	27.50	1715
42 x 18	1.28	0.75	31.00	27.50	1755
42 x 20	1.28	0.80	31.00	27.50	1820
42 x 24	1.28	0.89	31.00	27.50	1980
42 x 30	1.28	1.03	31.00	27.50	2245
42 x 36	1.28	1.15	31.00	27.50	2600
48 x 12	1.42	0.75	34.00	30.50	2175
48 x 14	1.42	0.66	34.00	30.50	2195
48 x 16	1.42	0.70	34.00	30.50	2235
48 x 18	1.42	0.75	34.00	30.50	2275
48 x 20	1.42	0.80	34.00	30.50	2340
48 x 24	1.42	0.89	34.00	30.50	2500
48 x 30	1.42	1.03	34.00	30.50	3000
48 x 36	1.42	1.15	34.00	30.50	3115
48 x 42	1.42	1.28	34.00	30.50	3580
54 x 12	0.90	0.75	39.00	35.29	1990
54 x 14	0.90	0.66	39.00	35.29	2015
54 x 16	0.90	0.70	39.00	35.29	2055
54 x 18	0.90	0.75	39.00	35.29	2095
54 x 20	0.90	0.80	39.00	35.29	2160
54 x 24	0.90	0.89	39.00	35.29	2320
54 x 30	0.90	0.90	39.00	35.29	2585
54 x 36	0.90	0.90	39.00	35.29	2980
54 x 42	0.90	0.90	39.00	35.29	3395
54 x 48	0.90	0.90	39.00	35.29	3565

STAR[®] PIPE PRODUCTS

UCAT12.01
 * REGISTERED TRADEMARK OF STAR PIPE PRODUCTS





Flanged Fittings

ANSI/AWWA C110/A21.10

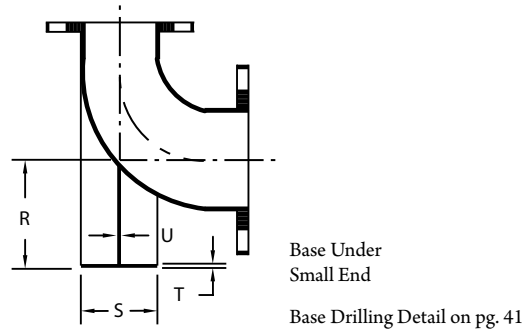
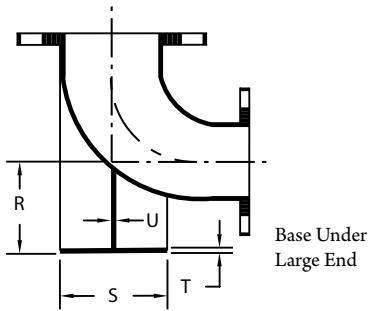

90° FLANGED REDUCING BASE BENDS

NOM. SIZE	R	S	T	U	WT (LBS.)
4 x 3	5.50	6.00	0.62	0.50	45
5 x 4	6.25	7.00	0.69	0.62	68
6 x 3	7.00	7.00	0.69	0.62	65
6 x 4	7.00	7.00	0.69	0.62	75
6 x 5	7.00	7.00	0.69	0.62	80
8 x 4	8.38	9.00	0.94	0.88	120
8 x 6	8.38	9.00	0.94	0.88	130
10 x 6	9.75	9.00	0.94	0.88	170
10 x 8	9.75	9.00	0.94	0.88	195
12 x 6	11.25	11.00	1.00	1.00	230
12 x 8	11.25	11.00	1.00	1.00	255
12 x 10	11.25	11.00	1.00	1.00	285
14 x 6	12.50	11.00	1.00	1.00	214
14 x 8	12.50	11.00	1.00	1.00	270
14 x 10	12.50	11.00	1.00	1.00	310
14 x 12	12.50	11.00	1.00	1.00	340
16 x 6	13.75	11.00	1.00	1.00	295
16 x 8	13.75	11.00	1.00	1.00	315
16 x 10	13.75	11.00	1.00	1.00	355
16 x 12	13.75	11.00	1.00	1.00	385
16 x 14	13.75	11.00	1.00	1.00	405
18 x 6	15.00	13.50	1.12	1.12	375
18 x 8	15.00	13.50	1.12	1.12	395
18 x 10	15.00	13.50	1.12	1.12	435
18 x 12	15.00	13.50	1.12	1.12	465
18 x 14	15.00	13.50	1.12	1.12	485
18 x 16	15.00	13.50	1.12	1.12	525
20 x 6	16.00	13.50	1.12	1.12	440
20 x 8	16.00	13.50	1.12	1.12	465
20 x 10	16.00	13.50	1.12	1.12	505
20 x 12	16.00	13.50	1.12	1.12	535
20 x 14	16.00	13.50	1.12	1.12	555
20 x 16	16.00	13.50	1.12	1.12	595
20 x 18	16.00	13.50	1.12	1.12	635
24 x 6	18.50	13.50	1.12	1.12	610
24 x 8	18.50	13.50	1.12	1.12	635
24 x 10	18.50	13.50	1.12	1.12	675
24 x 12	18.50	13.50	1.12	1.12	705
24 x 14	18.50	13.50	1.12	1.12	725
24 x 16	18.50	13.50	1.12	1.12	765
24 x 18	18.50	13.50	1.12	1.12	805

90° FLANGED REDUCING BASE BENDS (Con't)

NOM. SIZE	R	S	T	U	WT (LBS.)
24 x 20	18.50	13.50	1.12	1.12	870
30 x 12	23.00	16.00	1.19	1.15	1030
30 x 14	23.00	16.00	1.19	1.15	1050
30 x 16	23.00	16.00	1.19	1.15	1090
30 x 18	23.00	16.00	1.19	1.15	1130
30 x 20	23.00	16.00	1.19	1.15	1195
30 x 24	23.00	16.00	1.19	1.15	1355
36 x 12	26.00	19.00	1.25	1.15	1445
36 x 14	26.00	19.00	1.25	1.15	1465
36 x 16	26.00	19.00	1.25	1.15	1505
36 x 18	26.00	19.00	1.25	1.15	1545
36 x 20	26.00	19.00	1.25	1.15	1610
36 x 24	26.00	19.00	1.25	1.15	1770
36 x 30	26.00	19.00	1.25	1.15	2035
42 x 12	30.00	23.50	1.44	1.28	2065
42 x 14	30.00	23.50	1.44	1.28	2085
42 x 16	30.00	23.50	1.44	1.28	2125
42 x 18	30.00	23.50	1.44	1.28	2165
42 x 20	30.00	23.50	1.44	1.28	2230
42 x 24	30.00	23.50	1.44	1.28	2390
42 x 30	30.00	23.50	1.44	1.28	2655
42 x 36	30.00	23.50	1.44	1.28	3010
48 x 12	34.00	25.00	1.56	1.42	2690
48 x 14	34.00	25.00	1.56	1.42	2710
48 x 16	34.00	25.00	1.56	1.42	2750
48 x 18	34.00	25.00	1.56	1.42	2790
48 x 20	34.00	25.00	1.56	1.42	2855
48 x 24	34.00	25.00	1.56	1.42	3015
48 x 30	34.00	25.00	1.56	1.42	3280
48 x 36	34.00	25.00	1.56	1.42	3630
48 x 42	34.00	25.00	1.56	1.42	4095
54 x 12	38.00	27.50	1.69	1.55	2665
54 x 14	38.00	27.50	1.69	1.55	2690
54 x 16	38.00	27.50	1.69	1.55	2730
54 x 18	38.00	27.50	1.69	1.55	2770
54 x 20	38.00	27.50	1.69	1.55	2835
54 x 24	38.00	27.50	1.69	1.55	2995
54 x 30	38.00	27.50	1.69	1.55	3260
54 x 36	38.00	27.50	1.69	1.55	3615
54 x 42	38.00	27.50	1.69	1.55	4070
54 x 48	38.00	27.50	1.69	1.55	4240

STAR[®] PIPE PRODUCTS





Flanged Fittings

ANSI/AWWA C110/A21.10

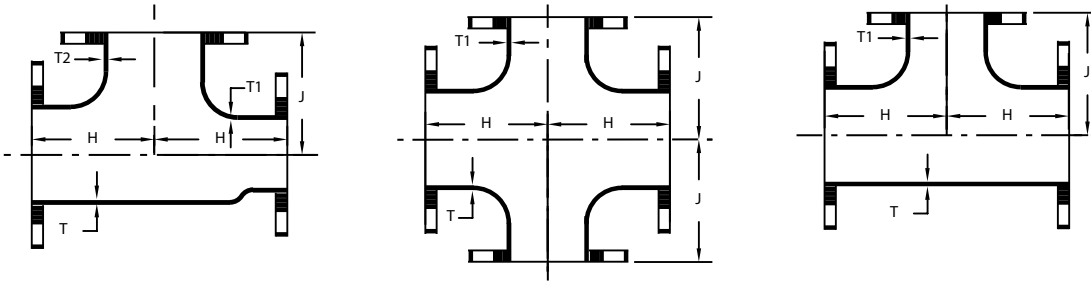

FLANGED TEES & CROSSES								
NOM. SIZE	T	T1	T2	H	J	WT. (LBS.)		
						TEE	CROSS	
1 1/2 x 1 1/2 x 2	0.31	0.31	0.31	4.50	4.50	15	---	
2 x 1 1/2 x 1 1/2	0.31	0.31	0.31	4.50	4.50	16	---	
2 x 2	0.31	0.31	---	4.50	4.50	20	---	
2 1/2 x 2 x 2	0.31	0.31	0.31	5.00	5.00	27	---	
2 1/2 x 2 x 2 1/2	0.31	0.31	0.31	5.00	5.00	28	---	
2 1/2 x 1	0.31	0.31	---	5.00	5.00	25	---	
2 1/2 x 1 1/2	0.31	0.31	---	5.00	5.00	26	---	
2 1/2 x 2 1/2	0.31	0.31	---	5.00	5.00	30	---	
3 x 1	0.48	0.31	---	5.50	5.50	32	---	
3 x 1 1/2	0.48	0.31	---	5.50	5.50	33	---	
3 x 2	0.48	0.31	---	5.50	5.50	35	45	
3 x 2 1/2	0.48	0.31	---	5.50	5.50	36	---	
3 x 3	0.48	0.48	---	5.50	5.50	40	50	
4 x 3 x 3	0.52	0.48	0.48	6.50	6.50	55	---	
4 x 2	0.52	0.31	---	6.50	6.50	50	60	
4 x 2 x 4	0.52	0.31	0.52	6.50	6.50	51	---	
4 x 2 1/2	0.52	0.31	---	6.50	6.50	56	65	
4 x 2 1/2 x 4	0.52	0.31	0.52	6.50	6.50	55	---	
4 x 3	0.52	0.48	---	6.50	6.50	60	70	
4 x 4	0.52	0.52	---	6.50	6.50	65	80	
4 x 4 x 5	0.50	0.50	0.50	7.50	7.50	75	---	
4 x 4 x 6	0.52	0.52	0.55	8.00	8.00	90	---	
5 x 2 1/2	0.50	0.31	---	7.50	7.50	73	---	
5 x 4	0.50	0.50	---	7.50	7.50	77	92	
5 x 5	0.50	0.50	---	7.50	7.50	80	---	
5 x 5 x 6	0.50	0.50	0.55	8.00	8.00	87	---	
6 x 3 x 3	0.55	0.48	0.48	8.00	8.00	75	---	
6 x 3 x 5	0.55	0.48	0.50	8.00	8.00	81	---	
6 x 4 x 4	0.55	0.52	0.52	8.00	8.00	85	---	
6 x 4 x 5	0.55	0.50	0.50	8.00	8.00	85	---	
6 x 4 x 6	0.55	0.52	0.55	8.00	8.00	90	---	
6 x 5 x 2 1/2	0.55	0.50	0.31	8.00	8.00	73	---	
6 x 5 x 3	0.55	0.50	0.48	8.00	8.00	81	---	
6 x 5 x 5	0.55	0.50	0.50	8.00	8.00	87	---	
6 x 2	0.55	0.31	---	8.00	8.00	82	90	
6 x 2 1/2	0.55	0.31	---	8.00	8.00	84	93	
6 x 3	0.55	0.48	---	8.00	8.00	85	95	
6 x 4	0.55	0.52	---	8.00	8.00	90	110	
6 x 5	0.55	0.50	---	8.00	8.00	91	115	
6 x 6	0.55	0.55	---	8.00	8.00	95	120	
6 x 6 x 8	0.55	0.55	0.60	9.00	9.00	140	---	
8 x 4 x 8	0.60	0.52	0.60	9.00	9.00	138	---	
8 x 5 x 4	0.60	0.50	0.50	9.00	9.00	126	---	
8 x 6 x 4	0.60	0.55	0.52	9.00	9.00	130	---	
8 x 6 x 6	0.60	0.55	0.55	9.00	9.00	135	---	

FLANGED TEES & CROSSES (Con't)								
NOM. SIZE	T	T1	T2	H	J	WT. (LBS.)		
						TEE	CROSS	
8 x 6 x 8	0.60	0.55	0.60	9.00	9.00	145	---	
8 x 2 1/2	0.60	0.31	---	9.00	9.00	128	---	
8 x 3	0.60	0.48	---	9.00	9.00	130	140	
8 x 4	0.60	0.52	---	9.00	9.00	140	155	
8 x 5	0.60	0.50	---	9.00	9.00	144	160	
8 x 6	0.60	0.55	---	9.00	9.00	145	165	
8 x 8	0.60	0.60	---	9.00	9.00	155	195	
8 x 8 x 10	0.60	0.60	0.68	11.00	11.00	260	---	
8 x 8 x 12	0.60	0.60	0.75	12.00	12.00	310	---	
10 x 4 x 10	0.68	0.52	0.68	11.00	11.00	250	---	
10 x 6 x 4	0.68	0.55	0.52	11.00	11.00	195	---	
10 x 6 x 6	0.68	0.55	0.55	11.00	11.00	200	---	
10 x 6 x 10	0.68	0.55	0.68	11.00	11.00	255	---	
10 x 8 x 6	0.68	0.60	0.55	11.00	11.00	210	---	
10 x 8 x 8	0.68	0.60	0.60	11.00	11.00	220	---	
10 x 8 x 10	0.68	0.60	0.68	11.00	11.00	265	---	
10 x 2	0.68	0.31	---	11.00	11.00	199	---	
10 x 3	0.68	0.48	---	11.00	11.00	201	---	
10 x 4	0.68	0.52	---	11.00	11.00	205	220	
10 x 5	0.68	0.50	---	11.00	11.00	211	230	
10 x 6	0.68	0.55	---	11.00	11.00	215	240	
10 x 8	0.68	0.60	---	11.00	11.00	225	265	
10 x 10	0.80	0.80	---	11.00	11.00	270	330	
10 x 10 x 12	0.68	0.68	0.75	12.00	12.00	355	---	
10 x 10 x 14	0.68	0.68	0.66	14.00	14.00	375	---	
12 x 6 x 6	0.75	0.55	0.55	12.00	12.00	325	---	
12 x 6 x 8	0.75	0.55	0.60	12.00	12.00	345	---	
12 x 8 x 6	0.75	0.60	0.55	12.00	12.00	340	---	
12 x 8 x 8	0.75	0.60	0.60	12.00	12.00	290	---	
12 x 8 x 12	0.75	0.60	0.75	12.00	12.00	365	---	
12 x 10 x 6	0.75	0.68	0.55	12.00	12.00	375	---	
12 x 10 x 8	0.75	0.68	0.60	12.00	12.00	380	---	
12 x 10 x 10	0.75	0.68	0.68	12.00	12.00	345	---	
12 x 10 x 12	0.75	0.68	0.75	12.00	12.00	370	---	
12 x 4	0.75	0.52	---	12.00	12.00	290	310	
12 x 5	0.75	0.50	---	12.00	12.00	291	315	
12 x 6	0.75	0.55	---	12.00	12.00	295	320	
12 x 8	0.75	0.60	---	12.00	12.00	310	345	
12 x 10	0.87	0.80	---	12.00	12.00	360	415	
12 x 12	0.87	0.87	---	12.00	12.00	385	460	
14 x 4	0.66	0.52	---	14.00	14.00	370	---	
14 x 6	0.66	0.55	---	14.00	14.00	375	400	

(Con't)➔

STAR[®] PIPE PRODUCTS

UCAT12.01
 * REGISTERED TRADEMARK OF STAR PIPE PRODUCTS





Flanged Fittings

ANSI/AWWA C110/A21.10

STAR[®] PIPE PRODUCTS

FLANGED TEES & CROSSES (Con't)							
NOM. SIZE	T	T1	T2	H	J	WT. (LBS.)	
						TEE	CROSS
14 x 8	0.66	0.60	---	14.00	14.00	390	425
14 x 10	0.66	0.68	---	14.00	14.00	400	460
14 x 12	0.66	0.75	---	14.00	14.00	425	505
14 x 14	0.66	0.66	---	14.00	14.00	435	530
16 x 4	0.70	0.52	---	15.00	15.00	460	---
16 x 6	0.70	0.55	---	15.00	15.00	465	490
16 x 8	0.70	0.60	---	15.00	15.00	475	520
16 x 10	0.70	0.68	---	15.00	15.00	495	555
16 x 12	0.70	0.75	---	15.00	15.00	520	605
16 x 14	0.70	0.66	---	15.00	15.00	585	620
16 x 16	0.70	0.70	---	15.00	15.00	550	665
18 x 6	0.75	0.55	---	13.00	15.50	480	505
18 x 8	0.75	0.60	---	13.00	15.50	495	535
18 x 10	0.75	0.68	---	13.00	15.50	510	560
18 x 12	0.75	0.75	---	13.00	15.50	535	610
18 x 14	0.75	0.66	---	16.50	16.50	630	720
18 x 16	0.75	0.70	---	16.50	16.50	650	765
18 x 18	0.75	0.75	---	16.50	16.50	665	795
20 x 6	0.80	0.55	---	14.00	17.00	610	635
20 x 8	0.80	0.60	---	14.00	17.00	620	665
20 x 10	0.80	0.68	---	14.00	17.00	635	685
20 x 12	0.80	0.75	---	14.00	17.00	660	735
20 x 14	0.80	0.66	---	14.00	17.00	665	745
20 x 16	0.80	0.70	---	18.00	18.00	810	915
20 x 18	0.80	0.75	---	18.00	18.00	820	945
20 x 20	0.80	0.80	---	18.00	18.00	885	1015
24 x 6	0.89	0.55	---	15.00	19.00	845	875
24 x 8	0.89	0.60	---	15.00	19.00	860	895
24 x 10	0.89	0.68	---	15.00	19.00	880	930
24 x 12	0.89	0.75	---	15.00	19.00	890	960
24 x 14	0.89	0.66	---	15.00	19.00	900	975
24 x 16	0.89	0.70	---	15.00	19.00	915	1010
24 x 18	0.89	0.75	---	22.00	22.00	1220	1365
24 x 20	0.89	0.80	---	22.00	22.00	1255	1430
24 x 24	0.89	0.89	---	22.00	22.00	1330	1570
30 x 6	1.03	0.55	---	18.00	23.00	1725	---
30 x 8	1.03	0.60	---	18.00	23.00	1460	---
30 x 10	1.03	0.68	---	18.00	23.00	1470	---
30 x 12	1.03	0.75	---	18.00	23.00	1490	1565
30 x 14	1.03	0.66	---	18.00	23.00	1490	1570
30 x 16	1.03	0.70	---	18.00	23.00	1505	1605
30 x 18	1.03	0.75	---	18.00	23.00	1515	1615
30 x 20	1.03	0.80	---	18.00	23.00	1540	1670
30 x 24	1.03	0.89	---	25.00	25.00	2025	2245
30 x 30	1.03	1.03	---	25.00	25.00	2150	2500
36 x 8	1.15	0.60	---	20.00	26.00	2140	---
36 x 10	1.15	0.68	---	20.00	26.00	2150	---
36 x 12	1.15	0.75	---	20.00	26.00	2170	2240
36 x 14	1.15	0.66	---	20.00	26.00	2175	2240
36 x 16	1.15	0.70	---	20.00	26.00	2185	2270
36 x 18	1.15	0.75	---	20.00	26.00	2190	2280
36 x 20	1.15	0.80	---	20.00	26.00	2210	2325
36 x 24	1.15	0.89	---	20.00	26.00	2255	2405
36 x 24 x 24	1.15	0.89	0.89	28.00	28.00	2670	---
36 x 30	1.15	1.03	---	28.00	28.00	3000	3300
36 x 36	1.15	1.15	---	28.00	28.00	3160	3620
36 x 30 x 30	1.15	1.03	1.03	28.00	28.00	2885	---

(Con't)▶

FLANGED TEES & CROSSES (Con't)							
NOM. SIZE	T	T1	T2	H	J	WT. (LBS.)	
						TEE	CROSS
36 x 36 x 48	1.15	1.15	1.42	34.00	34.00	4360	---
42 x 12	1.28	0.75	---	23.00	30.00	3165	3240
42 x 14	1.28	0.66	---	23.00	30.00	3170	3240
42 x 16	1.28	0.70	---	23.00	30.00	3180	3270
42 x 18	1.28	0.75	---	23.00	30.00	3185	3275
42 x 20	1.28	0.80	---	23.00	30.00	3205	3320
42 x 24	1.28	0.89	---	23.00	30.00	3245	3395
42 x 30	1.28	1.03	---	31.00	31.00	4125	4375
42 x 36	1.78	1.58	---	31.00	31.00	5360	5720
42 x 42	1.78	1.78	---	31.00	31.00	5580	6155
48 x 12	1.42	0.75	---	26.00	34.00	4315	4390
48 x 14	1.42	0.66	---	26.00	34.00	4315	4385
48 x 16	1.42	0.70	---	26.00	34.00	4330	4415
48 x 18	1.42	0.75	---	26.00	34.00	4330	4420
48 x 20	1.42	0.80	---	26.00	34.00	4350	4460
48 x 24	1.42	0.89	---	26.00	34.00	4385	4535
48 x 30	1.42	1.03	---	26.00	34.00	4455	4670
48 x 36	1.42	1.15	---	34.00	34.00	5555	5880
48 x 42	1.96	1.78	---	34.00	34.00	7195	7630
48 x 48	1.96	1.96	---	34.00	34.00	7385	8005
54 x 12	1.05	0.75	---	29.00	37.00	4435	4575
54 x 14	1.05	0.66	---	29.00	37.00	4435	4575
54 x 16	1.05	0.70	---	29.00	37.00	4450	4605
54 x 18	1.05	0.75	---	29.00	37.00	4460	4625
54 x 20	1.05	0.80	---	29.00	37.00	4480	4665
54 x 24	1.05	0.89	---	29.00	37.00	4515	4700
54 x 30	1.05	0.72	---	31.00	37.00	4615	4800
54 x 36	1.05	0.77	---	31.00	37.00	4695	4950
54 x 42	1.05	0.88	---	39.00	39.00	5740	6210
54 x 48	1.05	0.94	---	39.00	39.00	5850	6425
54 x 54	1.05	1.05	---	39.00	39.00	6025	6780
60 x 36	1.10	0.77	---	33.00	42.00	6015	6330
64 x 42	1.16	0.88	---	48.00	45.00	9610	10085
64 x 64	1.16	1.16	---	48.00	48.00	10995	12855

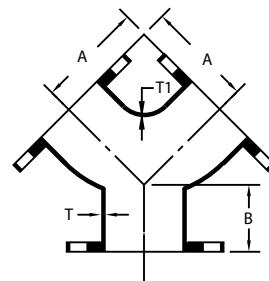

FLANGED TRUE WYE					
NOM. SIZE	T	T1	A	B	WT (LBS.)
3 x 3 x 3	0.48	0.48	5.50	2.50	32
4 x 4 x 4	0.52	0.52	6.50	3.00	50
6 x 4 x 4	0.55	0.52	8.00	3.50	75
6 x 6 x 6	0.55	0.55	8.00	3.50	80
8 x 6 x 6	0.60	0.55	9.00	4.50	120
8 x 8 x 8	0.60	0.60	9.00	4.50	125
10 x 8 x 8	0.68	0.60	11.00	5.00	155
12 x 12 x 12	0.75	0.75	12.00	5.50	300





Flanged Fittings

ANSI/AWWA C110/A21.10

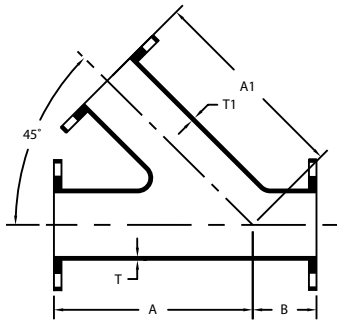

FLANGED WYE LATERALS						
NOM. SIZE	T	T1	A	A1	B	WT (LBS.)
3 x 3	0.48	0.48	10.00	10.00	3.00	45
4 x 3	0.52	0.48	12.00	12.00	3.00	65
4 x 4	0.52	0.52	12.00	12.00	3.00	75
6 x 4	0.55	0.52	14.50	14.50	3.50	105
6 x 6	0.55	0.55	14.50	14.50	3.50	120
8 x 4	0.60	0.52	17.50	17.50	4.50	165
8 x 6	0.60	0.55	17.50	17.50	4.50	175
8 x 8	0.60	0.60	17.50	17.50	4.50	200
10 x 4	0.68	0.52	20.50	20.50	5.00	240
10 x 6	0.68	0.55	20.50	20.50	5.00	250
10 x 8	0.68	0.60	20.50	20.50	5.00	335
10 x 10	0.68	0.68	20.50	20.50	5.00	335
12 x 4	0.75	0.52	24.50	24.50	5.50	350
12 x 6	0.75	0.55	24.50	24.50	5.50	427
12 x 8	0.75	0.60	24.50	24.50	5.50	452
12 x 10	0.75	0.68	24.50	24.50	5.50	420
12 x 12	0.75	0.75	24.50	24.50	5.50	515
14 x 6	0.66	0.55	27.00	27.00	6.00	475
14 x 8	0.66	0.60	27.00	27.00	6.00	500
14 x 10	0.66	0.68	27.00	27.00	6.00	525
14 x 12	0.66	0.75	27.00	27.00	6.00	570
14 x 14	0.66	0.66	27.00	27.00	6.00	605
16 x 6	0.70	0.55	30.00	30.00	6.50	620
16 x 8	0.70	0.60	30.00	30.00	6.50	645
16 x 10	0.70	0.68	30.00	30.00	6.50	736
16 x 12	0.70	0.75	30.00	30.00	6.50	792
16 x 14	0.70	0.66	30.00	30.00	6.50	755
16 x 16	0.70	0.70	30.00	30.00	6.50	805
18 x 8	0.75	0.60	32.00	32.00	7.00	780
18 x 10	0.75	0.68	32.00	32.00	7.00	810
18 x 12	0.75	0.75	32.00	32.00	7.00	850
18 x 14	0.75	0.66	32.00	32.00	7.00	885
18 x 16	0.75	0.70	32.00	32.00	7.00	935
18 x 18	0.75	0.75	32.00	32.00	7.00	980
20 x 10	0.80	0.68	35.00	35.00	8.00	1025
20 x 12	0.80	0.75	35.00	35.00	8.00	1065
20 x 14	0.80	0.66	35.00	35.00	8.00	1110
20 x 16	0.80	0.70	35.00	35.00	8.00	1155
20 x 20	0.80	0.80	35.00	35.00	8.00	1265
24 x 8	0.89	0.60	40.50	40.50	9.00	1425

(Con't)➔

FLANGED WYE LATERALS (Con't)						
NOM. SIZE	T	T1	A	A1	B	WT (LBS.)
24 x 10	0.89	0.68	40.50	40.50	9.00	1460
24 x 12	0.89	0.75	40.50	40.50	9.00	1550
24 x 14	0.89	0.66	40.50	40.50	9.00	1560
24 x 16	0.89	0.70	40.50	40.50	9.00	1615
24 x 18	0.89	0.75	40.50	40.50	9.00	1680
24 x 20	0.89	0.80	40.50	40.50	9.00	1750
24 x 24	0.89	0.89	40.50	40.50	9.00	1905
30 x 12	1.37	0.75	49.00	49.00	10.00	2545
30 x 14	1.37	0.66	49.00	49.00	10.00	2590
30 x 16	1.37	0.70	49.00	49.00	10.00	2645
30 x 18	1.37	0.96	49.00	49.00	10.00	2690
30 x 20	1.37	1.03	49.00	49.00	10.00	2760
30 x 24	1.37	1.16	49.00	49.00	10.00	2915
30 x 30	1.37	1.37	52.50	52.50	18.25	4130
36 x 12	1.58	0.75	60.00	60.00	19.50	4490
36 x 14	1.58	0.66	60.00	60.00	19.50	4545
36 x 16	1.58	0.89	60.00	60.00	19.50	4000
36 x 18	1.58	0.96	60.00	60.00	19.50	4670
36 x 20	1.58	1.03	60.00	60.00	19.50	4750
36 x 24	1.58	1.16	60.00	60.00	19.50	4920
36 x 30	1.58	1.37	56.00	56.00	15.25	5255
36 x 36	1.58	1.58	60.00	60.00	19.50	5740
42 x 20	1.78	1.03	60.00	60.00	11.75	6680
42 x 24	1.78	1.16	60.00	60.00	11.75	6850
42 x 30	1.78	1.37	63.00	63.00	11.75	7185
42 x 36	1.78	1.58	66.00	66.00	12.00	7670
42 x 42	1.78	1.78	71.00	71.00	15.00	9185
48 x 18	1.96	0.96	65.00	65.00	9.00	7000
48 x 24	1.96	1.16	58.00	64.00	5.00	8695
48 x 30	1.96	1.37	63.00	68.00	9.00	5573
48 x 36	1.96	1.58	72.00	72.00	7.00	9515
48 x 42	1.96	1.78	77.00	77.00	12.00	11030
48 x 48	1.96	1.96	77.00	77.00	16.00	12115
54 x 24	1.55	0.89	67.00	67.00	5.00	6220
54 x 30	1.55	1.03	72.00	74.00	9.00	7478
54 x 36	1.55	1.15	76.00	76.00	9.00	7600
54 x 42	1.55	1.28	81.00	81.00	14.00	8930
54 x 48	1.55	1.42	86.00	86.00	18.00	9480
54 x 54	1.55	1.55	90.00	90.00	20.00	11780
60 x 30	1.67	1.03	76.00	79.00	5.00	9045
64 x 36	1.96	1.58	80.00	86.00	5.00	12634

STAR[®] PIPE PRODUCTS

UCAT12.01
 * REGISTERED TRADEMARK OF STAR PIPE PRODUCTS





Flanged Fittings

ANSI/AWWA C110/A21.10

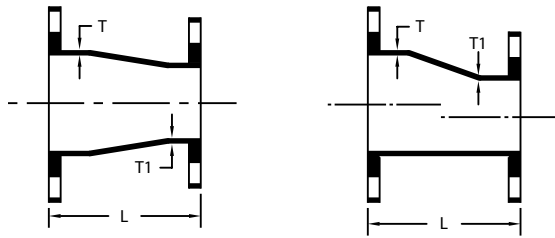

FE CONCENTRIC & ECCENTRIC REDUCERS

NOM. SIZE	T	T1	L	WT (LBS.)
2 x 1 1/2	0.31	0.31	5.50	10
2 1/2 x 2	0.31	0.31	5.50	14
3 x 2	0.48	0.31	6.00	16
3 x 2 1/2	0.48	0.31	6.00	21
4 x 2	0.52	0.31	7.00	25
4 x 2 1/2	0.52	0.31	7.00	28
4 x 3	0.52	0.48	7.00	30
5 x 2	0.50	0.31	8.00	34
5 x 2 1/2	0.50	0.31	8.00	35
5 x 3	0.50	0.48	8.00	37
5 x 4	0.50	0.50	8.00	41
6 x 1 1/2	0.55	0.31	9.00	33
6 x 2	0.55	0.31	9.00	35
6 x 2 1/2	0.55	0.31	9.00	38
6 x 3	0.55	0.48	9.00	40
6 x 4	0.55	0.52	9.00	45
6 x 5	0.55	0.52	9.00	52
8 x 3	0.60	0.48	11.00	60
8 x 4	0.60	0.52	11.00	65
8 x 5	0.60	0.52	11.00	70
8 x 6	0.60	0.55	11.00	75
10 x 3	0.68	0.48	12.00	81
10 x 4	0.68	0.52	12.00	85
10 x 6	0.68	0.55	12.00	90
10 x 8	0.68	0.60	12.00	110
12 x 4	0.75	0.52	14.00	120
12 x 5	0.75	0.50	14.00	126
12 x 6	0.75	0.55	14.00	130
12 x 8	0.75	0.60	14.00	145
12 x 10	0.75	0.68	14.00	170
14 x 6	0.66	0.55	16.00	155
14 x 8	0.66	0.60	16.00	175
14 x 10	0.66	0.68	16.00	190
14 x 12	0.66	0.75	16.00	248
16 x 6	0.70	0.55	18.00	190
16 x 8	0.70	0.60	18.00	210
16 x 10	0.70	0.68	18.00	235
16 x 12	0.70	0.75	18.00	265
16 x 14	0.70	0.66	18.00	280
18 x 8	0.75	0.60	19.00	240
18 x 10	0.75	0.68	19.00	265
18 x 12	0.75	0.75	19.00	295
18 x 14	0.75	0.66	19.00	310
18 x 16	0.75	0.70	19.00	340
20 x 8	0.80	0.60	20.00	290
20 x 10	0.80	0.68	20.00	310
20 x 12	0.80	0.75	20.00	345
20 x 14	0.80	0.66	20.00	355

(Con't)➔

FE CONCENTRIC & ECCENTRIC REDUCERS (Con't)

NOM. SIZE	T	T1	L	WT (LBS.)
20 x 16	0.80	0.70	20.00	390
20 x 18	0.80	0.75	20.00	410
24 x 10	0.89	0.68	24.00	450
24 x 12	0.89	0.75	24.00	480
24 x 14	0.89	0.66	24.00	490
24 x 16	0.89	0.70	24.00	525
24 x 18	0.89	0.75	24.00	550
24 x 20	0.89	0.80	24.00	590
30 x 8	1.03	0.60	30.00	700
30 x 12	1.03	0.75	30.00	730
30 x 14	1.03	0.66	30.00	745
30 x 16	1.03	0.70	30.00	770
30 x 18	1.03	0.75	30.00	810
30 x 20	1.03	0.80	30.00	870
30 x 24	1.03	0.89	30.00	970
36 x 16	1.15	0.70	36.00	1105
36 x 20	1.15	0.80	36.00	1230
36 x 24	1.15	0.89	36.00	1345
36 x 30	1.15	1.03	36.00	1555
42 x 20	1.28	0.80	42.00	1712
42 x 24	1.28	0.89	42.00	1820
42 x 30	1.28	1.03	42.00	2060
42 x 36	1.28	1.15	42.00	2550
48 x 30	1.42	1.03	48.00	2625
48 x 36	1.42	1.15	48.00	2950
48 x 42	1.42	1.28	48.00	3320
54 x 24	0.90	0.89	32.00	1820
54 x 30	0.90	0.61	32.00	1625
54 x 36	0.90	0.66	28.00	1680
54 x 42	0.90	0.76	25.00	1800
54 x 48	0.90	0.80	18.00	1695
60 x 54	0.94	0.90	15.00	2055

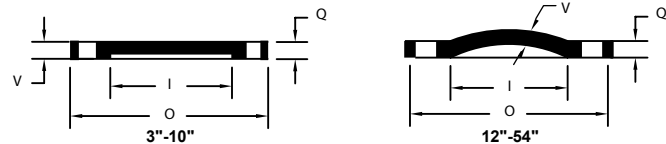

BLIND FLANGES (SOLID OR TAPPED)

NOM. SIZE	O	Q	V	I	WT (LBS.)
3	7.50	0.75	0.69	3.00	9
4	9.00	0.94	0.88	4.00	16
6	11.00	1.00	0.94	6.00	25
8	13.50	1.12	1.06	8.00	42
10	16.00	1.19	1.12	10.00	63
12	19.00	1.25	0.81	12.00	85
14	21.00	1.38	0.88	14.00	120
16	23.50	1.44	1.00	16.00	145
18	25.00	1.56	1.06	18.00	195
20	27.50	1.69	1.12	20.00	245
24	32.00	1.88	1.25	24.00	370
30	38.75	2.12	1.44	30.00	500
36	46.00	2.38	1.62	36.00	960
42	53.00	2.62	1.81	42.00	1300
48	59.50	2.75	2.00	48.00	1740
54	66.25	3.00	2.50	54.00	2600

STAR[®] PIPE PRODUCTS



UCAT.12.01
* REGISTERED TRADEMARK OF STAR PIPE PRODUCTS

STAR PIPE PRODUCTS
HOUSTON CORPORATE TOLL FREE 1-800-999-3009 FAX 281-558-9000
www.starpipeproducts.com



Flanged Fittings

ANSI/AWWA C110/A21.10

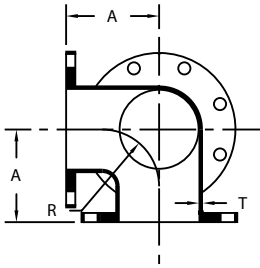

90° FLANGED SIDE OUTLET BEND				
NOM. SIZE	T	A	R	WT (LBS.)
3	0.48	5.50	4.00	35
4	0.52	6.50	4.50	60
6	0.55	8.00	6.00	95
8	0.60	9.00	7.00	145
10	0.68	11.00	9.00	240
12	0.75	12.00	10.00	345
14	0.66	14.00	11.50	478

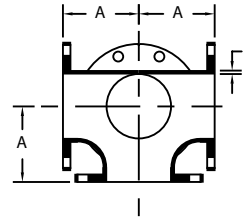

FLANGED SIDE OUTLET TEE			
NOM. SIZE	T	A	WT (LBS.)
4 x 4	0.52	6.50	80
6 x 6	0.55	8.00	120
8 x 8	0.60	9.00	195
10 x 10	0.68	11.00	284

GENERAL SPECIFICATIONS

- HEX BOLTS:** Per ANSI/ASME B18.2.1
Material Per ASTM A307 GRADE B, Zinc Plated
- HEX NUTS:** Per ANSI/ASME B18.2.2
Material Per ASTM A563 Grade A or B, Zinc Plated
- GASKETS:** 1/8" Thick Full Face Per ANSI/AWWA C110/A21.10 and ANSI/AWWA C111/A21.11
Material Per ASTM D1330 Grade II or ASTM D-2000 AA,
Color RED (Temperature Range - 20° F to 170° F)

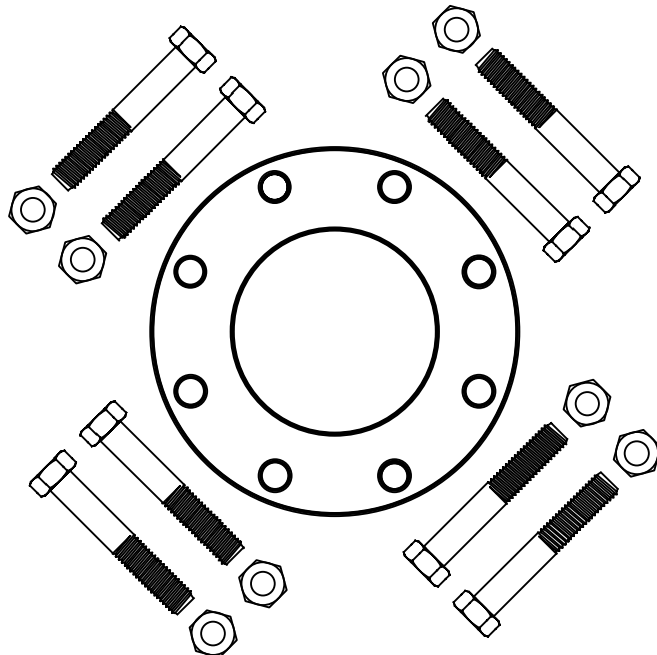

FLANGE ACCESSORY PACKS C111/A.21.11			
NOM. SIZE	BOLTS	QTY.	WT (LBS.)
1 1/2	1/2 x 2	4	1
2	5/8 x 2 1/4	4	1.4
2 1/2	5/8 x 2 1/2	4	1.8
3	5/8 x 2 1/2	4	2
4	3/8 x 3	8	3
5	3/4 x 3	8	5
6	3/4 x 3 1/2	8	5
8	3/4 x 3 1/2	8	6
10	7/8 x 4	12	12
12	7/8 x 4	12	13
14	1 x 4 1/2	12	19
16	1 x 4 1/2	16	25
18	1 1/8 x 5	16	35
20	1 1/8 x 5	20	45
24	1 1/4 x 5 1/2	20	63
30	1 1/4 x 6 1/2	28	95
36	1 1/2 x 7	32	170
42	1 1/2 x 7 1/2	36	215
48	1 1/2 x 8	44	265
54	1 3/4 x 8 1/2	44	390
60	1 3/4 x 9	52	500
64	1 3/4 x 9	52	500

