

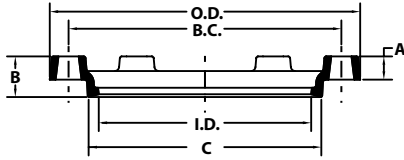

Compact MJ Fittings

ANSI/AWWA C153/A21.53



★ MJ GLANDS									
NOM. SIZE	O.D.	A	B	C	I.D.	B.C.	BOLT HOLE	BOLT QTY	WT (LBS.)
2	6.12	0.62	1.12	3.40	2.61	4.75	Ø0.75	2	1
3	7.69	0.62	1.37	4.84	4.06	6.19	Ø0.75	4	2
4	9.12	0.75	1.50	5.92	4.90	7.50	Ø0.88	4	3
6	11.12	0.88	1.63	8.02	7.00	9.50	Ø0.88	6	5
8	13.37	1.00	1.75	10.17	9.15	11.75	Ø0.88	6	6
10	15.62	1.00	1.75	12.22	11.20	14.00	Ø0.88	8	8
12	17.88	1.00	1.75	14.32	13.30	16.25	Ø0.88	8	9
14	20.25	1.25	2.00	16.40	15.44	18.75	Ø0.88	10	13
16	22.50	1.31	2.06	18.50	17.54	21.00	Ø0.88	12	17
18	24.83	1.38	2.13	20.60	19.64	23.25	Ø0.88	12	30
20	27.08	1.44	2.19	22.70	21.74	25.50	Ø0.88	14	35
24	31.58	1.56	2.31	26.90	25.94	30.00	Ø0.88	16	50
30	39.12	2.00	2.75	33.29	32.17	36.88	Ø1.13	20	85
36	46.00	2.00	2.75	39.59	38.47	43.75	Ø1.13	24	115
42	53.12	2.00	2.75	45.79	44.67	50.62	Ø1.38	28	143
48	60.00	2.00	2.75	52.09	50.97	57.50	Ø1.38	32	237
54	{ Dimensions Available On Request }								
60									
64									

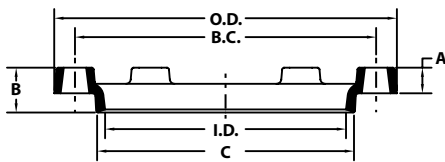

★ MJ OVERSIZE GLANDS									
NOM. SIZE	O.D.	A	B	C	I.D.	B.C.	BOLT HOLE	BOLT QTY	WT (LBS.)
4	9.12	0.75	1.50	5.92	5.10	7.50	Ø0.88	4	3
6	11.12	0.88	1.63	8.02	7.20	9.50	Ø0.88	6	5
8	13.37	1.00	1.75	10.17	9.40	11.75	Ø0.88	6	6
10	15.62	1.00	1.75	12.22	11.50	14.00	Ø0.88	8	8
12	17.88	1.00	1.75	14.32	13.60	16.25	Ø0.88	8	9
16	22.50	1.31	2.06	18.50	17.90	21.00	Ø0.88	12	17

STAR[®] PIPE PRODUCTS





Compact MJ Fittings

ANSI/AWWA C153/A21.53

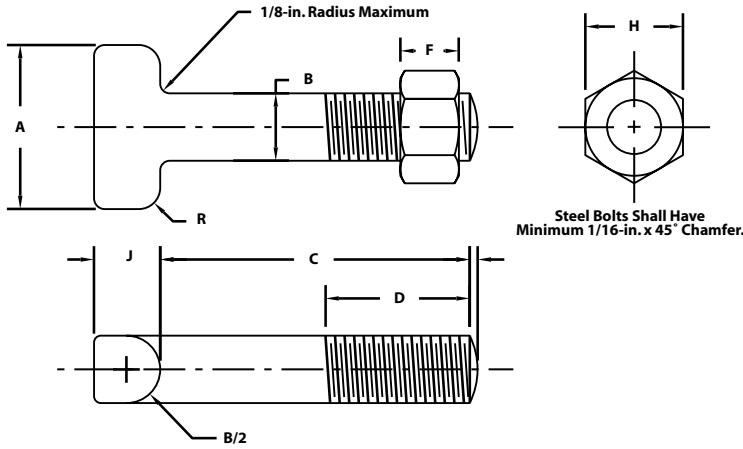

★ T-HEAD (LOW ALLOY STEEL) BOLT & NUTS

NOM. SIZE	A	B	C	D	THREADS PER IN.	F	H	J	R
5/8 x 3	1.50	0.625	3.00	2.00	11	0.625	1.062	0.625	0.312
5/8 x 3 1/2	1.50	0.625	3.50	2.70	11	0.625	1.062	0.625	0.312
3/4 x 3 1/2	1.75	0.750	3.50	2.50	10	0.750	1.250	0.750	0.375
3/4 x 4	1.75	0.750	4.00	3.00	10	0.750	1.250	0.750	0.375
3/4 x 4 1/2	1.75	0.750	4.50	3.00	10	0.750	1.250	0.750	0.375
3/4 x 5	1.75	0.750	5.00	3.00	10	0.750	1.250	0.750	0.375
3/4 x 5 1/2	1.75	0.750	5.50	3.70	10	0.750	1.250	0.750	0.375
1 x 6	2.25	1.000	6.00	3.00	8	1.000	1.625	1.000	0.500
1 1/4 x 6 1/2	2.50	1.250	6.50	3.50	7	1.250	2.000	1.250	0.625

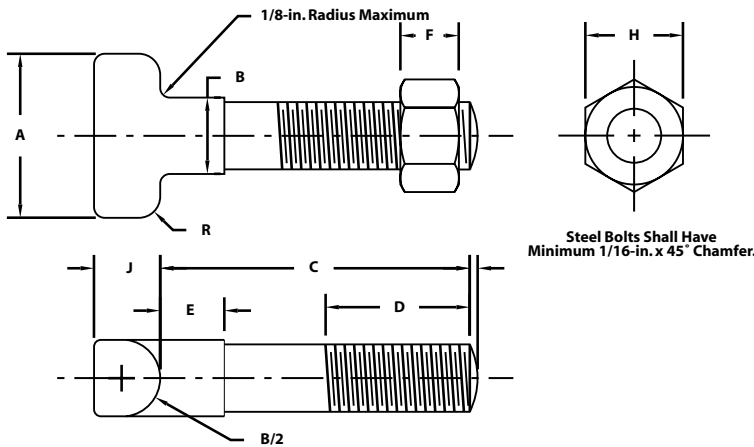

★ ANTI-ROTATION T-HEAD (LOW ALLOY STEEL) BOLT & NUTS

NOM. SIZE	A	B	C	D	E	THREADS PER IN.	F	H	J	R
5/8 x 3	1.50	0.625	3.00	2.00	0.63	11	0.625	1.062	0.625	0.312
5/8 x 3 1/2	1.75	0.750	3.50	2.50	0.63	10	0.750	1.250	0.750	0.375
3/4 x 4	1.75	0.750	4.00	3.00	0.63	10	0.750	1.250	0.750	0.375
3/4 x 4 1/2	1.75	0.750	4.50	3.00	0.63	10	0.750	1.250	0.750	0.375
3/4 x 5	1.75	0.750	5.00	3.00	0.63	10	0.750	1.250	0.750	0.375

REV. 07

® REGISTERED TRADEMARK OF STAR PIPE PRODUCTS

★Not Included in AWWA C153

STAR® PIPE PRODUCTS
HOUSTON CORPORATE | TOLL FREE 1-800-999-3009 | FAX 281-558-9000
www.starpipeproducts.com



STAR® PIPE PRODUCTS



Compact MJ Fittings

ANSI/AWWA C153/A21.53

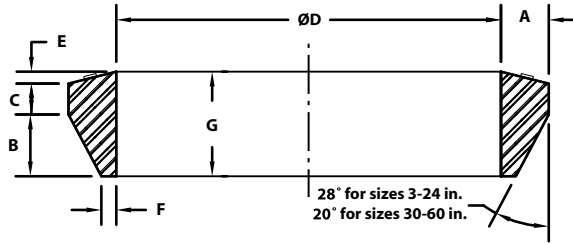
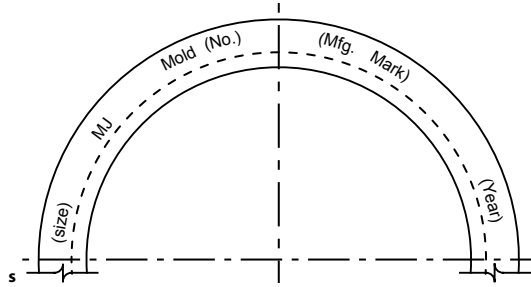

MECHANICAL-JOINT GASKET								
NOM. SIZE	PIPE O.D.	A	B	C	ØD ±1 %	E	F	G
2	2.50	0.48	0.62	0.31	2.48	0.12	0.15	1.05
3	3.96	0.48	0.62	0.31	3.86	0.12	0.15	1.05
4	4.80	0.62	0.75	0.31	4.68	0.16	0.22	1.22
6	6.90	0.62	0.75	0.31	6.73	0.16	0.22	1.22
8	9.05	0.62	0.75	0.31	8.85	0.16	0.22	1.22
10	11.10	0.62	0.75	0.31	10.87	0.16	0.22	1.22
12	13.20	0.62	0.75	0.31	12.95	0.16	0.22	1.22
14	15.30	0.62	0.75	0.31	14.99	0.16	0.22	1.22
16	17.40	0.62	0.75	0.31	17.07	0.16	0.22	1.22
18	19.50	0.62	0.75	0.31	19.13	0.16	0.22	1.22
20	21.60	0.62	0.75	0.31	21.20	0.16	0.22	1.22
24	25.80	0.62	0.75	0.31	25.34	0.16	0.22	1.22
30	32.00	0.73	1.00	0.38	31.47	0.16	0.37	1.54
36	38.30	0.73	1.00	0.38	37.67	0.16	0.37	1.54
42	44.50	0.73	1.00	0.38	43.78	0.16	0.37	1.54
48	50.80	0.73	1.00	0.38	49.98	0.16	0.37	1.54
54	{ Dimensions Available On Request }							
60								
64								

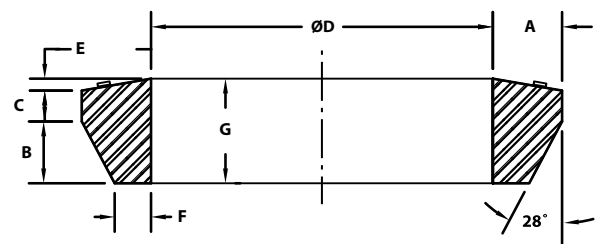
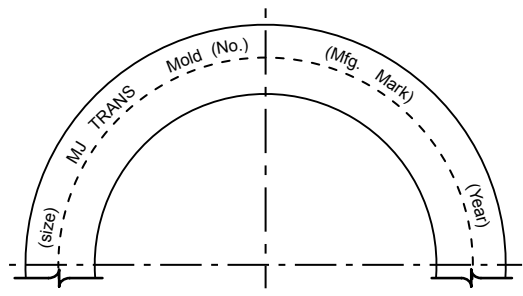

★ TRANSITION MECHANICAL-JOINT GASKET								
NOM. SIZE	PIPE O.D.	A	B	C (REF.)	ØD ±1 %	E	F	G
2	2.375	0.56	0.66	0.31	2.32	0.12	0.21	1.10
3	3.500	0.72	0.64	0.34	3.43	0.12	0.38	1.10
4	4.500	0.76	0.73	0.33	4.43	0.20	0.37	1.26
6	6.625	0.75	0.73	0.32	6.53	0.20	0.36	1.25
8	8.625	0.82	0.73	0.34	8.50	0.20	0.43	1.27
10	10.750	0.79	0.75	0.31	10.59	0.20	0.39	1.26
12	12.750	0.84	0.75	0.33	12.56	0.20	0.44	1.28

STAR[®] PIPE PRODUCTS



★Not Included in AWWA C153

REV.07
® REGISTERED TRADEMARK OF STAR PIPE PRODUCTS

STAR[®] PIPE PRODUCTS
HOUSTON CORPORATE | TOLL FREE 1-800-999-3009 | FAX 281-558-9000
www.starpipeproducts.com