

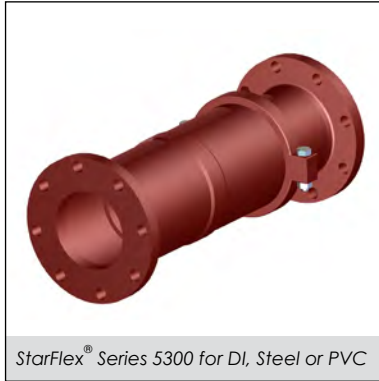

# StarFlex® series 5300

Flexible Expansion Joint  
for the Protection of Water Wastewater, and Industrial Pipelines



StarFlex® Series 5300 for DI, Steel or PVC

### SUBMITTAL INFORMATION

PROJECT NAME:

ENGINEER:

CONTRACTOR:

SPEC. SECTION:



### FEATURES & ADVANTAGES

- Each StarFlex™ is coated inside and outside with 15 mils of Fusion Bonded Epoxy that is NSF compliant.
- Every unit is pressurized and cycled while maintaining 350 PSI on sizes 3" - 24", 250 PSI on sizes 30" and above.
- Each unit is shipped in a cradle at its preset position, but can be adjusted to the desired dimension in the field.
- All sizes have external EPDM rubber boots to prevent debris from entering the sealing areas.
- Pressure seals are EPDM. Maximum operating temperature is 175° F.
- The StarFlex™ may be used on ductile iron, steel, HDPE or PVC pipe.
- Flanged outlets are dimensioned according to ANSI/AWWA C110/A21.11 which is also equal to ASME B16.1 Class 124 & ASME B16.5 Class 150 without a raised face.
- NSF61 Approved Fusion Bonded Epoxy coating is used in wetted areas.

**Note:** Starflex™ series 5000, 5100 and 5300 flexible expansion joints are designed to expand when internally pressurized. End thrust generated from expansion of the Starflex™ under internal pressure must be accommodated in the piping system design.

### MATERIAL SPECIFICATIONS:

- All cast components are made entirely of Ductile Iron per ASTM A536, Grade 65-45-12
- All fasteners are Type 304 Stainless Steel.

STAR® PIPE PRODUCTS





**StarFlex<sup>®</sup> series 5300**

Flexible Expansion Joint

for the Protection of Water, Wastewater, and Industrial Pipelines

STAR<sup>®</sup> PIPE PRODUCTS

Please check sizes:

STARFLEX <sup>®</sup> 5300 SPECIFICATIONS*				
NOM. SIZE	A (OD)	EXPANSION <sup>1</sup>	C (LENGTH)	WEIGHT (LBS)
3	7.50	+2 /-2	18.90	47
	7.50	+4 /-4	32.68	75
	7.50	+6 /-6	46.46	103
	7.50	+8 /-8	60.24	131
4	9.00	+2 /-2	19.29	63
	9.00	+4 /-4	33.07	99
	9.00	+6 /-6	46.85	134
	9.00	+8 /-8	60.63	170
6	11.00	+2 /-2	19.69	90
	11.00	+4 /-4	33.46	141
	11.00	+6 /-6	47.24	192
	11.00	+8 /-8	61.02	243
8	13.50	+2 /-2	20.47	126
	13.50	+4 /-4	34.25	190
	13.50	+6 /-6	48.03	255
	13.50	+8 /-8	61.81	319
10	16.00	+2 /-2	21.46	173
	16.00	+4 /-4	35.63	251
	16.00	+6 /-6	49.80	328
	16.00	+8 /-8	63.98	406
12	19.00	+2 /-2	22.05	213
	19.00	+4 /-4	36.22	306
	19.00	+6 /-6	50.39	398
	19.00	+8 /-8	64.57	490
14	21.00	+4 /-4	33.86	424
	21.00	+8 /-8	62.20	701
	21.00	+18 /-6	90.55	978
16	23.50	+4 /-4	34.06	500
	23.50	+8 /-8	62.01	817
	23.50	+18 /-6	89.96	1134
18	25.00	+4 /-4	34.65	554
	25.00	+8 /-8	62.20	904
	25.00	+18 /-6	89.76	1254
20	27.50	+4 /-4	35.43	655
	27.50	+8 /-8	62.60	1049
	27.50	+18 /-6	89.76	1445
24	32.00	+4 /-4	36.61	871
	32.00	+8 /-8	63.19	1366
	32.00	+18 /-6	89.76	1861
30	38.75	+5 /-5	45.77	1690
	38.75	+10 /-10	77.76	2758
	38.75	+15 /-15	109.74	3826
36	46.00	+5 /-5	47.74	2314
	46.00	+10 /-10	80.12	3668
	46.00	+15 /-15	112.50	5023
48	64.59	+6 /-6	53.15	**

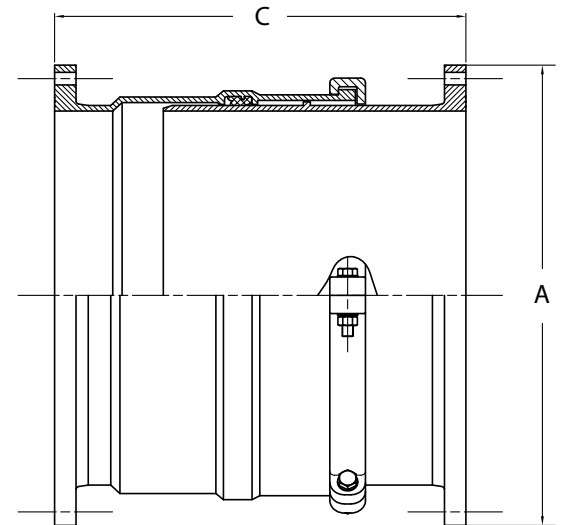

\* All dimensions in inches except where indicated.

\*\* Contact Star for details.

<sup>1</sup> For units of expansion that are not listed, please contact your Star<sup>®</sup> Pipe representative.

