

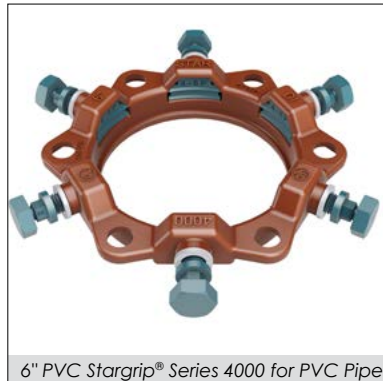

PVC Stargrip® series 4000

Mechanical Joint Wedge Action Restraint
for Plastic Pressure Pipe



6" PVC Stargrip® Series 4000 for PVC Pipe

SUBMITTAL INFORMATION

PROJECT NAME:

ENGINEER:

CONTRACTOR:

SPEC. SECTION:



FEATURES & ADVANTAGES

- The design has been proven in the market since 1992.
- Can be used on AWWA C900, AWWA C905 PVC pipe, IPS PVC pipe, AWWA C909 PVCO pipe, and HDPE pipe. See pressure rating table for approved DRs and sizes. Plastic pressure pipes manufactured to an IPS diameter regimen will require a transition gasket. HDPE pipe requires use of stainless steel pipe stiffener.
- Gland is made from high strength Ductile Iron per ASTM A536 Grade 65-45-12 and is compatible with all Mechanical Joints conforming to ANSI/AWWA C111/A21.11.
- Eliminates the need for tie rods and thrust blocks
- Listed with Underwriters Laboratories and approved by Factory Mutual research in sizes 4"-12".
- Tested to and meets the requirements of ASTM F1674 through 14".
- The safety factor is twice (2:1) the standardized pressure rating listed on next page.
- Will fit any Mechanical Joint configuration, meaning compatibility with different types of installations.
- PVC Stargrip® offers 5° deflection through 12", 3° on 14"-24" and 2° on 30"-36".
- Larger ID allows easier installation on out-of-round pipe.
- Torque limiting bolts are designed to prevent over torquing.
- All sizes have curved wedges that do not flatten pipe.
- Standard gland color is Coral Red (RAL 3016).

MATERIAL SPECIFICATIONS:

- Gland: Ductile Iron per ASTM A536, Grade 65-45-12
- Wedges: Ductile Iron per ASTM A536, Grade 65-45-12
 - ♦ Wedge Finish: Thermally cured fluoropolymer epoxy coating

GLAND FINISH OPTIONS (Please check one):

- Standard: alkyd enamel coating
- Optional: Starbond™ TGIC polyester powder coating applied by an electrostatic spray process
- Optional: Other (specify) _____

COUNTRY OF ORIGIN OPTION (Please check one):

- Import
 - 100% Domestic¹
 - Domestic gland with import components¹
- ¹(Please see [Domestic Restraint Options Available](#) on our website.)

HARDWARE OPTIONS (Please check):

- Standard: T-bolts and nuts are high strength low alloy steel manufactured in accordance with ANSI/AWWA C111/A21.11
- Optional: T-bolts alloy SS 304 per ASTM F593; Nuts alloy SS 304 per ASTM F594 CW
- Optional: T-bolts alloy SS 316 per ASTM F593; Nuts alloy SS 316 per ASTM A194 Grade 8M
- Optional: T-bolts and nuts Fluoropolymer Star-Blue coated high strength low alloy steel manufactured in accordance with ANSI/AWWA C111/A21.11

STAR® PIPE PRODUCTS

REV.17.01



® REGISTERED TRADEMARK OF STAR PIPE PRODUCTS

STAR® PIPE PRODUCTS
HOUSTON CORPORATE | TOLL FREE 1-800-999-3009 | FAX 281-558-9000
www.starpipeproducts.com



PVC Stargrip® series 4000

Mechanical Joint Wedge Action Restraint
for Plastic Pressure Pipe

TECHNICAL INFORMATION

Please check sizes:

PVC STARGRIP® 4000 SPECIFICATIONS*							
NOM. SIZE	ØA	B	C¹	ØD	T-BOLTS SIZE (QTY)	WEDGES (QTY)	APPROX WT. (LBS)
3	4.09	7.69	8.50	3/4	5/8 (4)	4	7
4	4.93	9.12	9.53	7/8	3/4 (4)	4	9
6	7.03	11.12	11.63	7/8	3/4 (6)	6	13
8	9.18	13.37	13.97	7/8	3/4 (6)	6	17
10	11.23	15.62	16.18	7/8	3/4 (8)	8	23
12	13.33	17.87	18.18	7/8	3/4 (8)	8	28
14	15.45	20.75	20.36	7/8	3/4 (10)	10	50
16	17.55	23.00	22.46	7/8	3/4 (12)	12	60
18	19.65	25.25	24.56	7/8	3/4 (12)	12	65
20	21.75	27.50	26.66	7/8	3/4 (14)	14	76
24	25.95	32.00	30.86	7/8	3/4 (16)	16	98
30	32.18	39.38	36.82	1-1/8	1 (20)	20	173
36	38.48	46.25	43.12	1-1/8	1 (24)	24	219

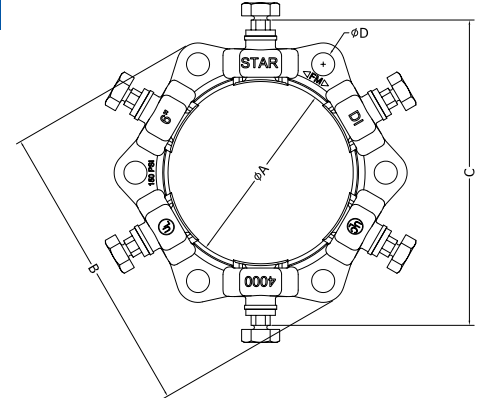

6" PVC Stargrip® Series 4000

*All dimensions in inches except where indicated.
1 - dimension after assembly on pipe

Table A. Maximum Working Pressure Rating with Occasional or Recurring Surges in PSI for Plastic Pipes Made to a CIOD Diameter Regimen

NOM. SIZE (IN)	Actual Plastic Pipe OD	AWWA C900 PVC			AWWA C905 PVC				AWWA C909 PVCO			AWWA C906 HDPE*					
		DR14	DR18	DR25	DR18	DR21	DR25	DR32.5	IPEX PVCO		JM EAGLE PVCO	DR 7.3	DR 9	DR 9.3	DR11	DR13.5	DR17
									PC235	PC235							
4	4.80	305	235	165					235			254	200	193	160	130	100
6	6.90	305	235	165					235	235		254	200	193	160	130	100
8	9.05	305	235	165					235	235		254	200	193	160	130	100
10	11.10	305	235	165					235	235		254	200	193	160	130	100
12	13.20	305	235	165					235	235		254	200	193	160	130	100
14	15.30				235	200	165	125	235				200	193	160		
16	17.40				235	200	165	125	235		165				160		
18	19.50				235	200	165	125	200						160		
20	21.60				235	200	165	125									
24	25.80				235	200	165	125									
30	32.00						165	125									
36	38.30						165	125									

* A stainless steel pipe stiffener (provided by others) is required for the Series 4000 to be installed on HDPE pressure pipe. The stiffener must be installed in the HDPE pipe before installing the Series 4000. The stainless steel pipe stiffener must be of sufficient length to support the full bearing length of the restrainer.

Table B. Maximum Working Pressure Rating with Occasional or Recurring Surges in PSI for Plastic Pipes Made to an IPS Diameter Regimen

NOM. SIZE (IN)	Actual Plastic Pipe OD	ASTM D2241 PVC			AWWA C901 and AWWA C906 HDPE**						
		SDR17	SDR21	SDR26	DR 7.3	DR 9	DR 9.3	DR11	DR13.5	DR17	
3	3.50	250	200	160	254	200			160	130	100
4	4.50	250	200	160	254	200	193		160	130	100
6	6.63	250	200	160	254	200	193		160	130	100
8	8.63	250	200	160	254	200	193		160	130	100
10	10.75	250	200	160	254	200	193		160	130	100
12	12.75	250	200	160	254	200	193		160	130	100

NOTE: A transition gasket is required for use with pipes made to an IPS diameter regimen.

** A stainless steel pipe stiffener (provided by others) is required for the Series 4000 to be installed on HDPE pressure pipe. The stiffener must be installed in the HDPE pipe before installing the Series 4000. The stainless steel pipe stiffener must be of sufficient length to support the full bearing length of the restrainer.

STAR® PIPE PRODUCTS