

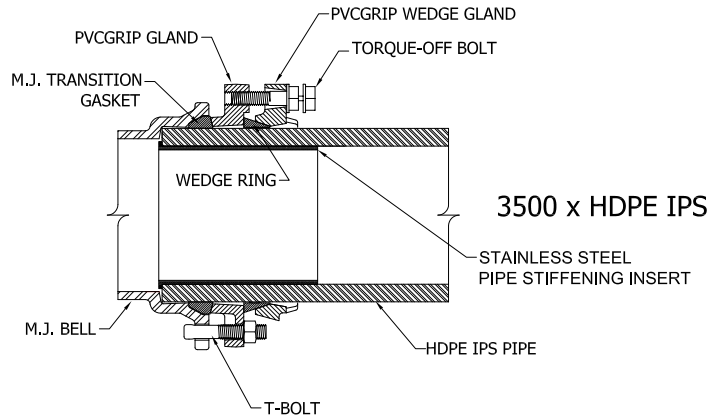

PVC Ring Lock (PVCGrip™) Series 3500 Restrainer

FOR USE ON HDPE PIPE WITH IPS O.D.

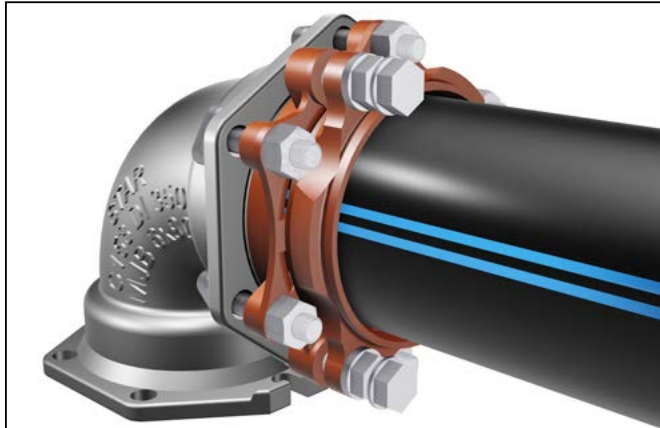

FEATURES & BENEFITS

- Designed for Restraining Mechanical Joint Fittings with IPS HDPE pipe per ANSI/AWWA C906.
- MJ transition gasket required on IPS HDPE pipe
- Castings made of Ductile Iron per ASTM A536, Grade 65-45-12.
- Pressure rating equal to full pressure rating of the pipe for which it is installed on, derated as required for service temperature, per ANSI/AWWA C906, Table 10.
- Maintains full 5° deflection through 10" on Mechanical Joints.
- T-Bolts/Rods/Hex Nuts: High Strength Low Alloy Steel Per ANSI/AWWA C111/A21.11
- Series 3500 Restrainer is intended for underground use only.

PRESSURE RATINGS FOR HDPE PIPE WITH IRON PIPE SIZE O.D.

Nominal Size	HDPE PIPE OD	Maximum Pressure Ratings (PSI)				T-Bolt Torque (LB.-FT.)
		DR 11	DR 9.3	DR 9	DR 7.3	
4"	4.50	160	193	200	254	75-90
6"	6.63	160	193	200	254	75-90
8"	8.63	160	193	200	254	75-90
10"	10.75	160	193	200	254	75-90

NOTES

- Stainless Steel Pipe Stiffeners (Not supplied by STAR) must be installed in the HDPE pipe before assembling PVC Ring Lock.
- Pipe stiffeners must be of sufficient length to support the full bearing length of the restrainer.
- Installation requires T- Bolt torque values to be applied as indicated above.
- Installation and testing to be in accordance with ANSI/AWWA C600
- Not approved for use on 12" HDPE IPS O.D. pipe

STAR® PIPE PRODUCTS

