

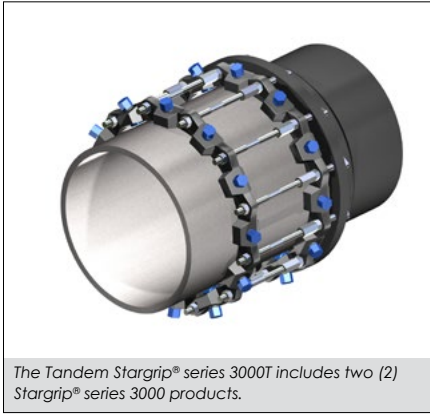

Tandem Stargrip® series 3000T

For High Pressure DI Pipe to MJ Fitting Applications



The Tandem Stargrip® series 3000T includes two (2) Stargrip® series 3000 products.

SUBMITTAL INFORMATION

PROJECT NAME:

ENGINEER:

CONTRACTOR:

SPEC. SECTION:



FEATURES & ADVANTAGES

- The Wedge Assembly is designed with a Break-Off Torque Control Nut that will only break off in one direction, ensuring proper installation.
- The Stargrip® offers a full 5° deflection through 12" size, 3° on 14"-24", 2° on 30"-36" and 1° on 42"-48".
- Minimum safety factor of 2:1
- The Wedge Assembly is designed to fit specific pipe sizes and is field repairable.
- No special tools are required for installation of the Stargrip®.
- Stargrip® may also be used on steel pipe* up to 12" (***transition gasket required on 12" and under**). For 14" and larger steel applications, contact Star Pipe.

MATERIAL SPECIFICATIONS:

- Gland: Ductile Iron per ASTM A536, Grade 65-45-12
- Wedges: Ductile Iron per ASTM A536, Grade 65-45-12 heat treated to a minimum of 370 BHN
 - ♦ Wedge Finish: Thermally cured fluoropolymer epoxy coating

GLAND FINISH OPTIONS (Please check one):

- Standard: alkyd enamel coating
- Optional: Starbond™ TGIC polyester powder coating applied by an electrostatic spray process
- Optional: Other (specify) _____

COUNTRY OF ORIGIN OPTION (Please check one):

- Import
 - 100% Domestic¹
 - Domestic gland with import components¹
- ¹(Please see [Domestic Restraint Options Available](#) on our website.)

HARDWARE OPTIONS (Please check one):

- Standard: T-bolts and bolt rods are high strength low alloy steel manufactured in accordance with ANSI/AWWA C111/A21.11-00
- Optional: T-bolts, bolt rods, and nuts alloy SS 304 per ASTM F593
- Optional: T-bolts, bolt rods, and nuts alloy SS 316 per ASTM F593
- Optional: T-bolts, bolt rods and nuts Fluoropolymer Star-Blue coated high strength low alloy steel manufactured in accordance with ANSI/AWWA C111/A21.11-00



STAR® PIPE PRODUCTS



Tandem Stargrip® series 3000T

For High Pressure DI Pipe to MJ Fitting Applications

TECHNICAL INFORMATION

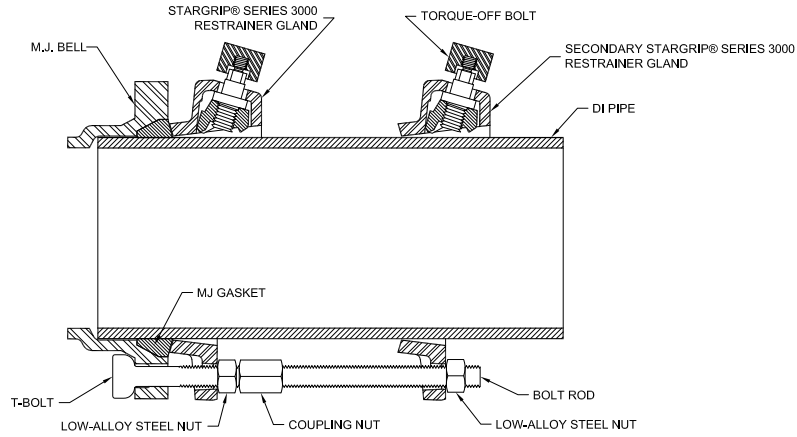

STAR® PIPE PRODUCTS

DATA FOR HIGH PRESSURE STARGRIP® ASSEMBLY

Please check sizes:

NOM. SIZE	DI PIPE OD	PRESSURE RATING (PSI)	BOLT ROD SIZE	T-BOLT SIZE	T-BOLT TORQUE (FT-LBS)	COUPLING NUT-GRADE 5 STEEL	WT
3	3.96	700	5/8 x 6	5/8 x 4	45-60	5/8 x 2 1/8	18
4	4.80	700	3/4 x 12	3/4 x 4 1/2	75-90	3/4 x 2 1/4	28
6	6.90	700	3/4 x 12	3/4 x 4 1/2	75-90	3/4 x 2 1/4	41
8	9.05	700	3/4 x 12	3/4 x 4 1/2	75-90	3/4 x 2 1/4	49
10	11.10	600	3/4 x 12	3/4 x 4 1/2	75-90	3/4 x 2 1/4	69
12	13.20	600	3/4 x 12	3/4 x 5	75-90	3/4 x 2 1/4	88
14	15.30	500	3/4 x 12	3/4 x 5	90-110	3/4 x 2 1/4	141
16	17.40	500	3/4 x 12	3/4 x 5	90-110	3/4 x 2 1/4	159
18	19.50	350	3/4 x 12	3/4 x 5	120-140	3/4 x 2 1/4	177
20	21.60	350	3/4 x 12	3/4 x 5 1/2	120-140	3/4 x 2 1/4	191
24	25.80	350	3/4 x 12	3/4 x 5 1/2	120-140	3/4 x 2 1/4	294
30	32.00	300	1 x 12	1 x 6 1/2	120-140	1 x 2 3/4	520
36	38.30	300	1 x 12	1 x 7 1/2	120-140	1 x 2 3/4	616
42	44.50	300	1 1/4 x 12	1 1/4 x 8 1/2	120-150	1 1/4 x 3	1118
48	50.80	300	1 1/4 x 12	1 1/4 x 8 1/2	120-150	1 1/4 x 3	1357

**All dimensions in inches except where indicated.*

